

Mathy Taffy

Jean-Luc Thiffeault (with Chef Keith Green)

@jeanluc_t 

Department of Mathematics
University of Wisconsin – Madison

Wisconsin Science Festival
5 November 2017

Supported by NSF grants DMS-0806821 and CMMI-1233935





play movie <http://www.youtube.com/watch?v=pCLYieehzGs>

taffy pullers



play movie

play movie

http://www.youtube.com/watch?v=YPP2_Zf0IVU

making candy cane



[Wired: This Is How You Craft 16,000 Candy Canes in a Day]

a simple taffy puller



initial 



σ_1

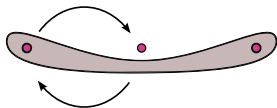

$\sigma_1 \sigma_2^{-1} \sigma_1$

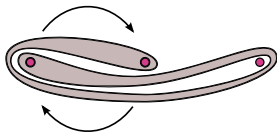

$\sigma_1 \sigma_2^{-1}$

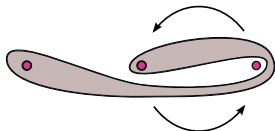

$\sigma_1 \sigma_2^{-1} \sigma_1 \sigma_2^{-1}$

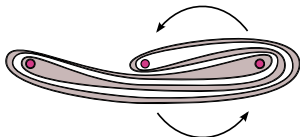



[Matlab: demo1]

Let's count alternating left/right folds. The sequence is

$$\#folds = 1, 1, 2, 3, 5, 8, 13, 21, 34, \dots$$

What is the rule?

$$\#folds_n = \#folds_{n-1} + \#folds_{n-2}$$

This is the famous **Fibonacci sequence**, F_n .

how fast does the taffy grow?



It is well-known that for large n ,

$$\frac{F_n}{F_{n-1}} \rightarrow \phi = \frac{1 + \sqrt{5}}{2} = 1.6180\dots$$

where ϕ is the **Golden Ratio**, also called the **Golden Mean**.

Along with π , ϕ is probably the best known number in mathematics. It seems to pop up everywhere. . .

So the ratio of lengths of the taffy between two successive steps is ϕ^2 , where the squared is due to the left/right alternation.

Hence, the **growth factor** for this taffy puller is

$$\phi^2 = \phi + 1 = 2.6180\dots$$

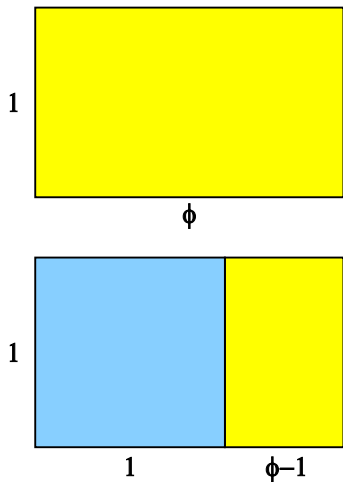

A rectangle has the proportions of the Golden Ratio if, after taking out a square, the remaining rectangle has the same proportions as the original:

$$\frac{\phi}{1} = \frac{1}{\phi - 1}$$

a slightly more complex taffy puller



[Matlab: demo2]

Now let's swap our prongs twice each time.

We get for the number of left/right folds

$$\#folds = 1, 2, 5, 12, 29, 70, 169, 408 \dots$$

This sequence is given by

$$\#folds_n = 2\#folds_{n-1} + \#folds_{n-2}$$

For large n ,

$$\frac{\#folds_n}{\#folds_{n-1}} \rightarrow \chi = 1 + \sqrt{2} = 2.4142 \dots$$

where χ is the **Silver Ratio**, a much less known number.

Hence, the **growth factor** for this taffy puller is

$$\chi^2 = 2\chi + 1 = 5.8284 \dots$$

the Silver Ratio, χ



A rectangle has the proportions of the Silver Ratio if, after taking out **two squares**, the remaining rectangle has the same proportions as the original.

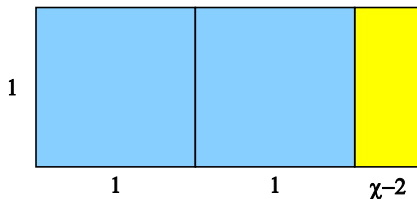

$$\frac{\chi}{1} = \frac{1}{\chi - 2}$$

$$\chi = 1 + \sqrt{2} = 2.4142 \dots$$

The standard 3-prong puller has growth χ^2 .

the history of taffy pullers



But who invented the well-known designs for taffy pullers? [Google patents](#) is an awesome resource.

The very first: Firchau (1893)

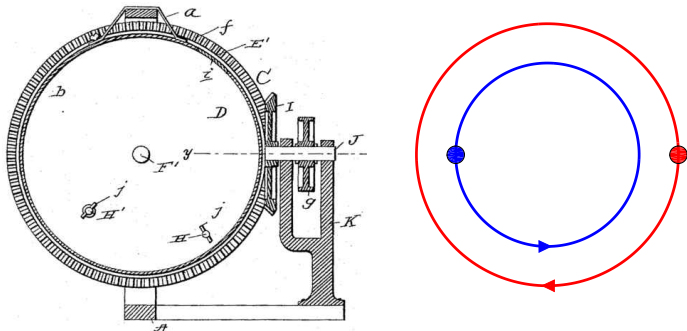

This is a terrible taffy puller. It was likely never built, but plays an important role later...

the first true taffy puller



I think Herbert M. Dickinson (1906, but filed in 1901) deserves the title of inventor of the first taffy puller:

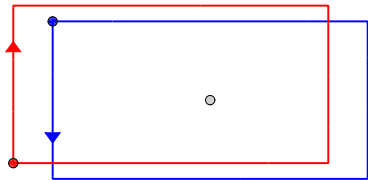
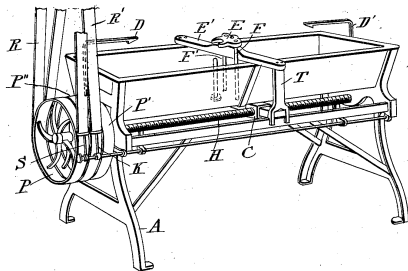

Awkward design: the moving prongs get 'tripped' each cycle. But it is topologically the same as the 3-prong device still in use today.

There seem to be questions as to whether it ever worked, or if it really pulled taffy rather than mixing candy.

the modern 3-prong design



Robinson & Deiter (1908) greatly simplified this design to one still in use today.

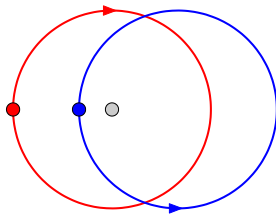
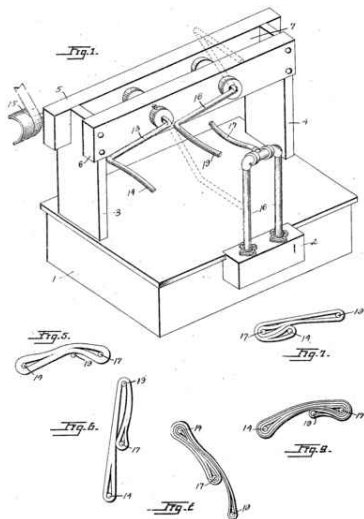

The uncontested taffy magnate of the early 20th century was Herbert L. Hildreth of Maine.



The Hotel Velvet in Old Orchard, Maine

His hotel was on the beach, and taffy was popular at such resorts. He sold it wholesale as well.

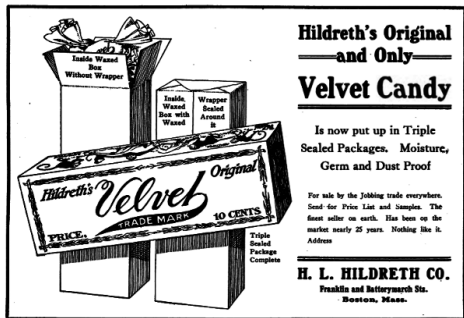

The Confectioners Gazette (1914)

the 4-prong design



The first 4-prong design is by Thibodeau (1903, filed 1901), an employee of Hildreth.

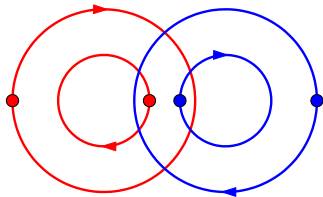
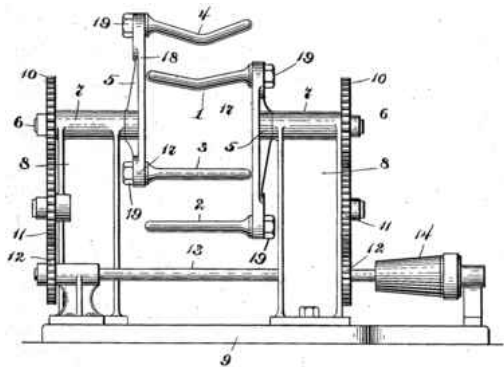

Hildreth was not pleased by this but bought the patent for \$75,000 (about two million of today's dollars).

4-prong taffy puller



play movie <http://www.youtube.com/watch?v=Y7t1HDSquVM>

the best patents have beautiful diagrams

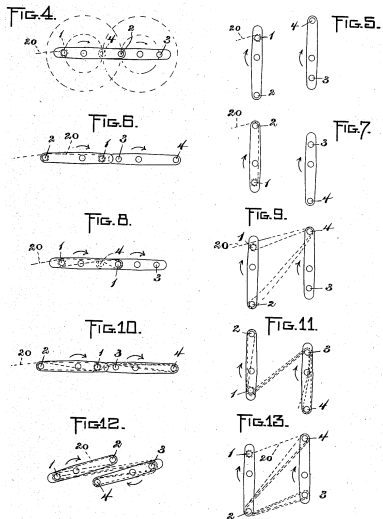

Thibodeau (1903)

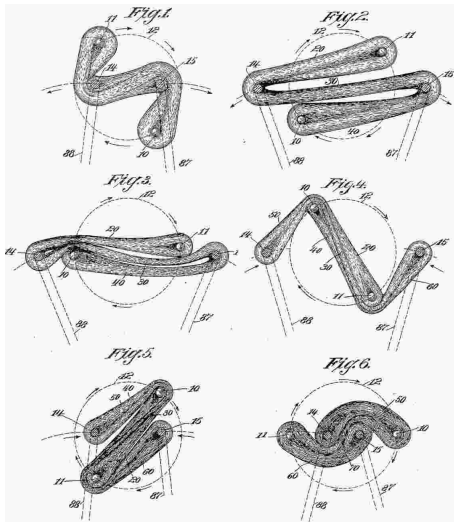

Richards (1905)



So many concurrent patents were filed that lawsuits ensued for more than a decade. Shockingly, the taffy patent wars went all the way to the **US Supreme Court**. The opinion of the Court was delivered by **Chief Justice William Howard Taft** (*Hildreth v. Mastoras*, 1921):

*The machine shown in the Firchau patent [has two pins that] pass each other twice during each revolution [...] and move in concentric circles, but do not have the relative in-and-out motion or Figure 8 movement of the Dickinson machine. With only two hooks there could be no lapping of the candy, because there was no third pin to re-engage the candy while it was held between the other two pins. The movement of the two pins in concentric circles might stretch it somewhat and stir it, **but it would not pull it in the sense of the art.***

The Supreme Court opinion displays the fundamental insight that at least three prongs are required to produce some sort of rapid growth.

A few designs are based on 'planetary' gears, such as McCarthy (1916):

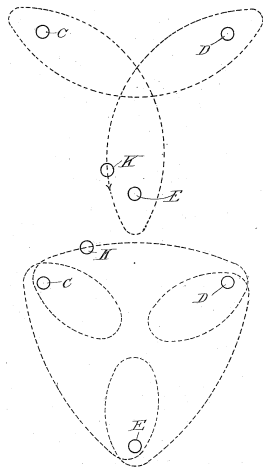
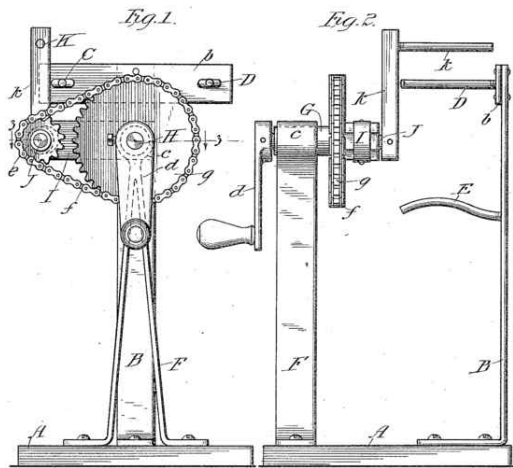

the mixograph



A modern planetary design is the **mixograph**, a device for measuring the properties of dough:

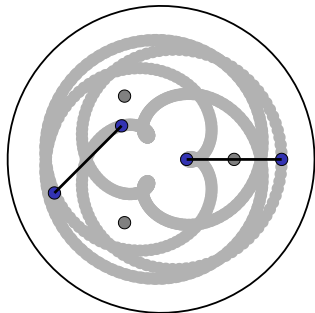

play movie

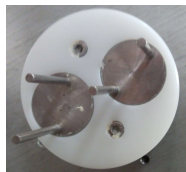
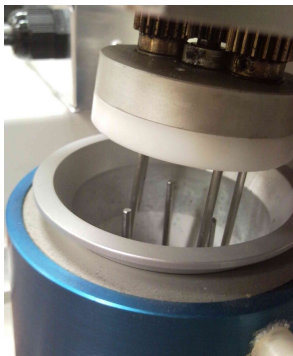

[Department of Food Science, University of Wisconsin. Photos by J-LT.]

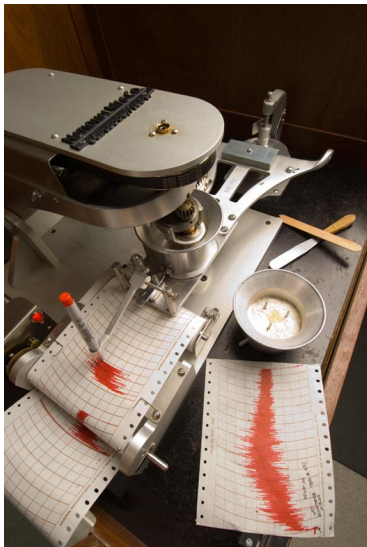

The mixograph measures the resistance of the dough to the pin motion.

This is graphed to determine properties of the dough, such as water absorption and 'peak time.'

There remains many patents that I call 'exotic' which use nonstandard motions: such as Jenner (1905):

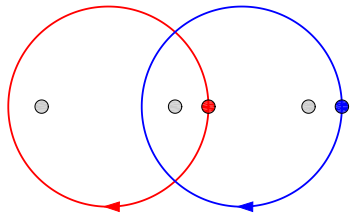
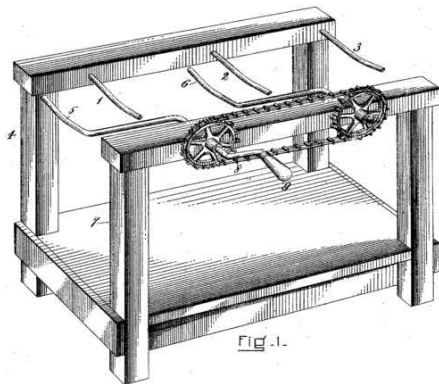

exotic designs (2)



Shean & Schmelz (1914):

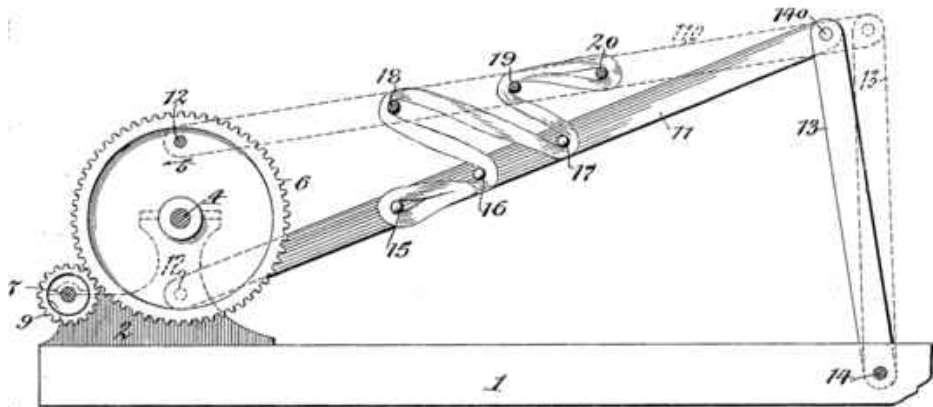

exotic designs (3)



My personal favorite, McCarthy & Wilson (1915):

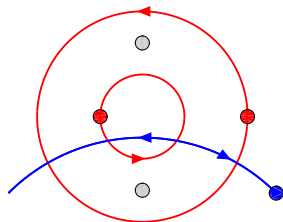
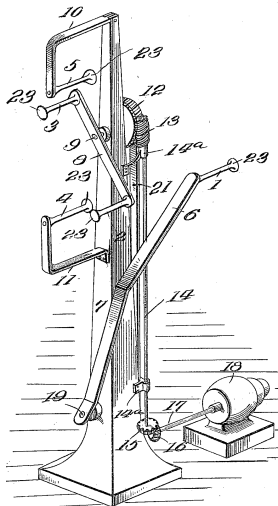

What about the taffy puller with four prongs?

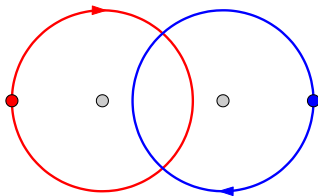

Does it stretch taffy faster or slower than the 3-prong one?

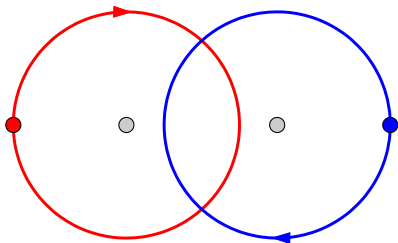
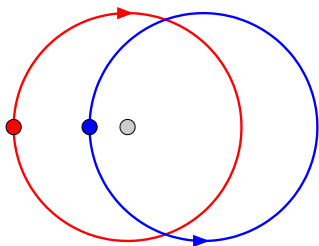

The two 'standard' pullers
have exactly the same taffy
growth factor,

$$3 + 2\sqrt{2} \simeq 5.82843.$$

can we improve the 4-prong puller?

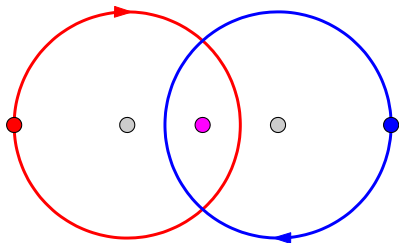
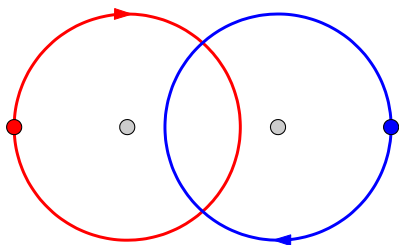

It would be nice to actually gain something from adding more prongs.

Try inserting another fixed prong.

Again, these two pullers have exactly the same taffy growth factor,

$$3 + 2\sqrt{2} \simeq 5.82843.$$

more prongs is sometimes better!

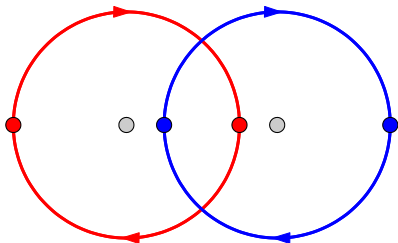
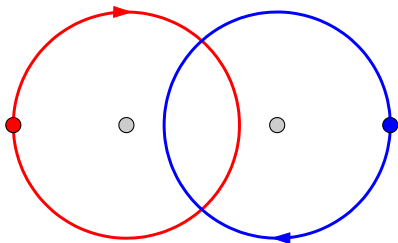

Start over!

Use two prongs per 'cycle.'

Now the taffy growth factor
of the bottom puller is

$$7 + 4\sqrt{3} \simeq 13.9282,$$

which is quite a bit larger
than 5.82843.

let's try our hand at this



Six-rod design with Alex Flanagan (undergrad at UW):

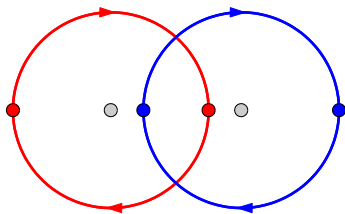
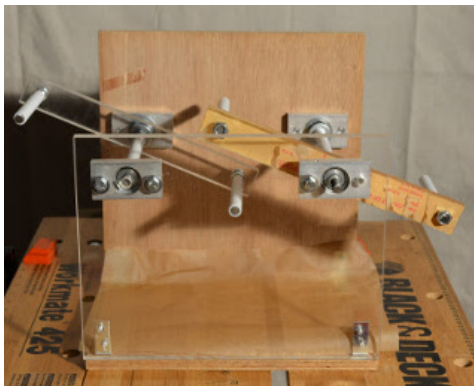

The software tools allow us to rapidly try designs. This one is simple and has huge growth (13.9 vs 5.8 for the standard pullers).

making taffy is hard



Early efforts yielded mixed results: . . . but eventually we got better at it

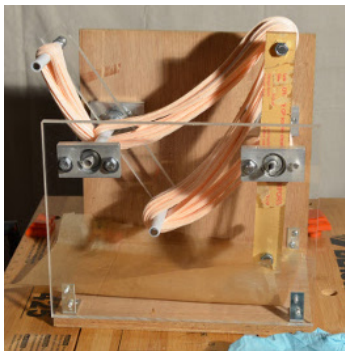
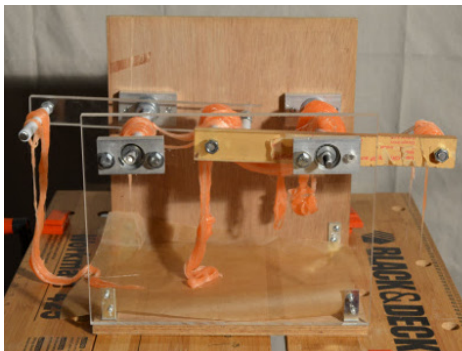

play movie

(BTW: The physics of candy making is fascinating. . .)



Dickinson, H. M. (1906).

Firchau, P. J. G. (1893).

Jenner, E. J. (1905).

McCarthy, E. F. (1916).

McCarthy, E. F. & Wilson, E. W. (1915).

Richards, F. H. (1905).

Robinson, E. M. & Deiter, J. H. (1908).

Shean, G. C. C. & Schmelz, L. (1914).

Thibodeau, C. (1903).