

# the mathematics of taffy pulling

Jean-Luc Thiffeault

@jeanluc\_t 

University of Wisconsin – Madison  
Department of Mathematics

Dynamical Systems Seminar

Dept. of Mathematics, University of Minnesota  
Minneapolis, MN, 15 November 2019

Supported by NSF grant CMMI-1233935



**WISCONSIN**  
UNIVERSITY OF WISCONSIN-MADISON

# the standard 3-pronged taffy puller



Taffy is a type of candy.

Needs to be **pulled**: this aerates it and makes it lighter and chewier.

We can assign a **growth**: length multiplier per period.

[movie by M. D. Finn]

play movie



# standard 4-pronged taffy puller



play movie

<http://www.youtube.com/watch?v=Y7t1HDSquVM>

[MacKay (2001); Halbert & Yorke (2014)]

# a simple taffy puller



initial

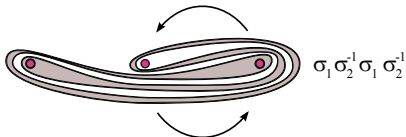
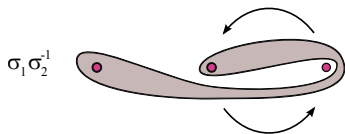
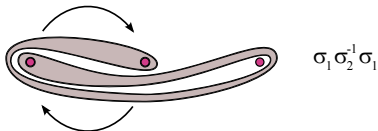
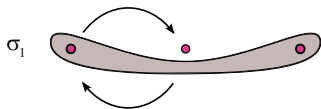

[Remark for later: each prong moves in a 'figure-eight' orbit.]

# the famous mural



This is the same action as in the famous mural painted at Berkeley by Thurston and Sullivan in the Fall of 1971:

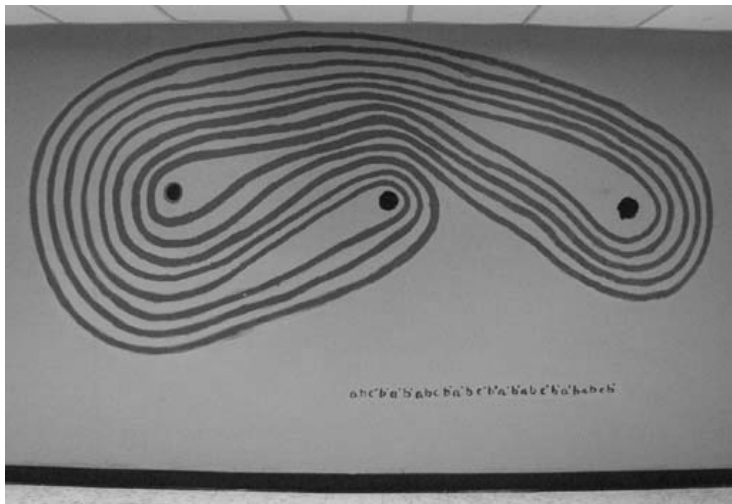



The simple taffy puller has a **growth factor** equal to

$$\phi^2 = \phi + 1 = 2.6180\dots$$

where  $\phi$  is the **Golden Ratio**.

Such quadratic numbers also arise for linear maps on the torus  $T^2$ , such as **Arnold's Cat Map**:

$$\begin{pmatrix} x \\ y \end{pmatrix} \mapsto \begin{pmatrix} 2 & 1 \\ 1 & 1 \end{pmatrix} \begin{pmatrix} x \\ y \end{pmatrix} \pmod{1}, \quad x, y \in [0, 1]^2$$

The largest eigenvalue of the matrix  $\begin{pmatrix} 2 & 1 \\ 1 & 1 \end{pmatrix}$  is  $\phi^2$ . Coincidence?

What's the connection between taffy pullers and these maps?

The 'standard model' for the torus is the biperiodic unit square:

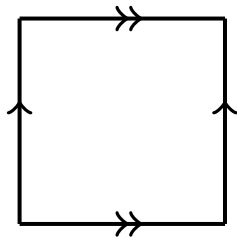
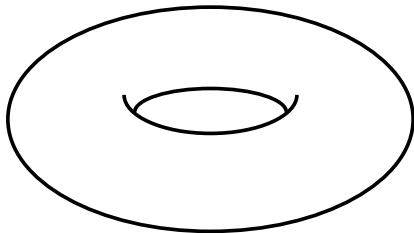

The Cat Map stretches loops exponentially:

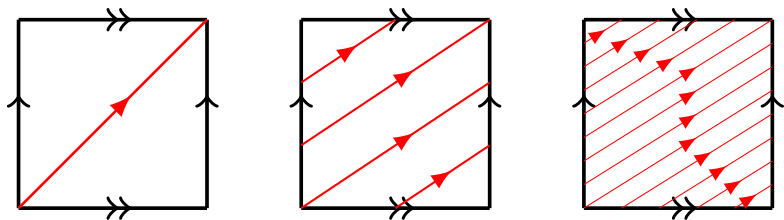

This loop will stand in for a piece of taffy.



# hyperelliptic involution



Consider the linear map  $\iota(x) = -x \bmod 1$ . This map is called the **hyperelliptic involution** ( $\iota^2 = \text{id}$ ).

Construct the quotient space

$$S = T^2 / \iota$$

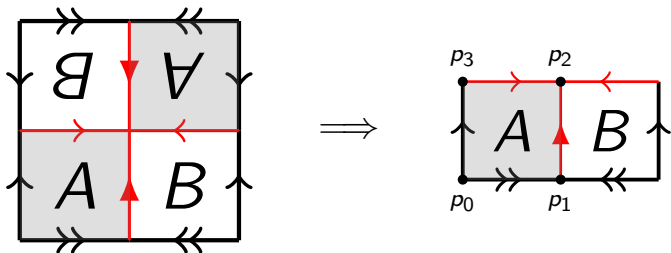

Claim: the surface  $S$  (right) is a sphere with four **punctures**!

# sphere with four punctures



Here's how we see that  $S$  is a sphere:

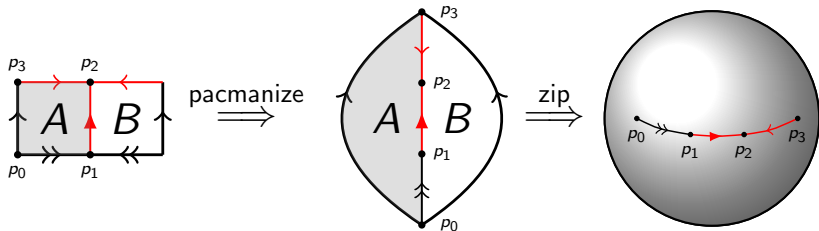

The punctures  $p_{1,2,3}$  are the **prongs of our taffy puller**.

(The fixed puncture  $p_0$  plays no role here, other than acting as a topological obstruction.)

Linear maps **commute with  $\iota$** , so all linear torus maps 'descend' to taffy puller motions.

Any 3-pronged taffy puller motion can be represented as a product of

$$\sigma_1 = \begin{pmatrix} 1 & 0 \\ 1 & 1 \end{pmatrix}, \quad \sigma_2 = \begin{pmatrix} 1 & -1 \\ 0 & 1 \end{pmatrix}$$

and their inverses, known as **Dehn twists**.

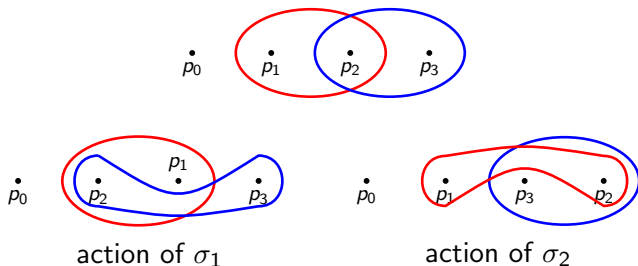

These can also be view as generators for the **braid group** for 3 strings.

By decomposing taffy puller motions as a product of the  $\sigma_1$  and  $\sigma_2$  operations, we can find the **growth factor** for any 3-pronged taffy puller.

For instance, the simple taffy puller has a motion  $\sigma_1\sigma_2^{-1}$  which we already saw gives a growth equal to the Cat Map's,  $\phi^2$ .

The standard 3-pronged taffy puller has a motion  $\sigma_1^2\sigma_2^{-2}$ , which has matrix representation

$$\begin{pmatrix} 5 & 2 \\ 2 & 1 \end{pmatrix}$$

with growth  $\chi^2 = (1 + \sqrt{2})^2$ , where  $\chi$  is the **Silver Ratio**.

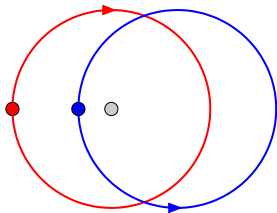

Surprisingly, the standard 4-pronged taffy puller has exactly the same growth factor.

## the Silver Ratio (2)



A rectangle has the proportions of the Silver Ratio if, after taking out **two squares**, the remaining rectangle has the same proportions as the original.

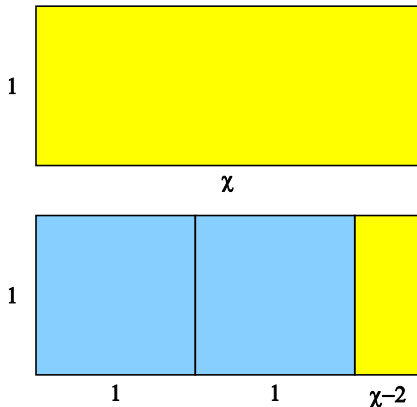

$$\frac{x}{1} = \frac{1}{x-2}$$

$$x = 1 + \sqrt{2} = 2.4142 \dots$$

Both major taffy puller designs (3- and 4-pronged) have growth  $x^2$ .

# the history of taffy pullers



But who invented the well-known designs for taffy pullers?

Google patents is an awesome resource.

The very first: Firchau (1893)

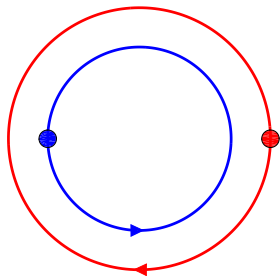
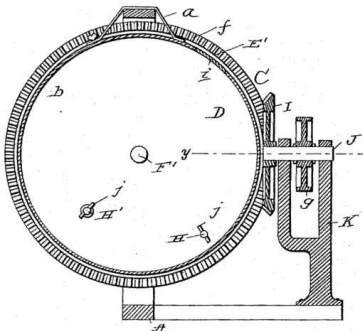

This is a terrible taffy puller. It was likely never built, but plays an important role in the looming...

A black and white photograph capturing a vast fleet of aircraft carriers and their escorts on the sea. The carriers are positioned in a line across the lower portion of the frame. Above them, hundreds of aircraft are flying in a dense, organized formation, filling the sky. The text "taffy patent wars" is overlaid in red on the center of the image.

**taffy patent wars**

# the first true taffy puller



I think Herbert M. Dickinson (1906, but filed in 1901) deserves the title of inventor of the first taffy puller:

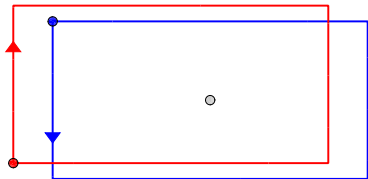
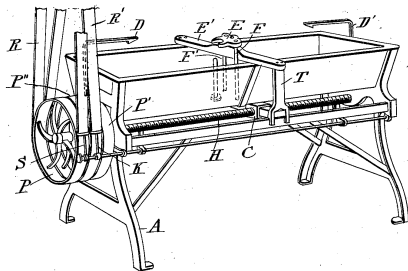

Awkward design: the moving prongs get 'tripped' each cycle. But it is topologically the same as the 3-pronged device still in use today.

There seem to be questions as to whether it ever worked, or if it really pulled taffy rather than mixing candy.



# the modern 3-pronged design



Robinson & Deiter (1908) greatly simplified this design to one still in use today.

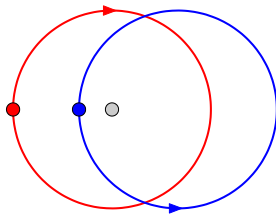
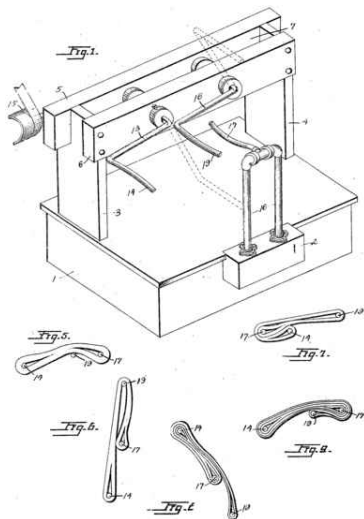

The uncontested taffy magnate of the early 20th century was Herbert L. Hildreth of Maine.



The Hotel Velvet in Old Orchard, Maine

His hotel was on the beach, and taffy was popular at such resorts. He sold it wholesale as well.

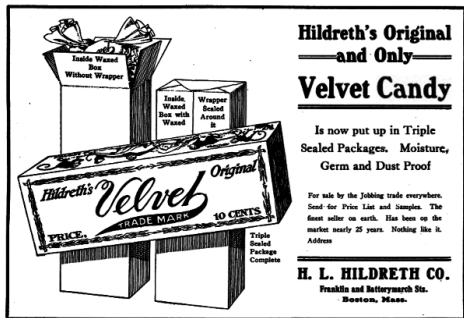

*The Confectioners Gazette* (1914)

# the 4-pronged design



The first 4-pronged design is by Thibodeau (1903, filed 1901), an employee of Hildreth.

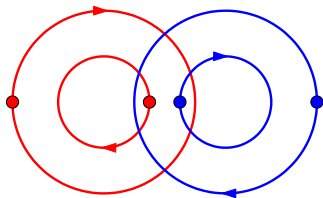
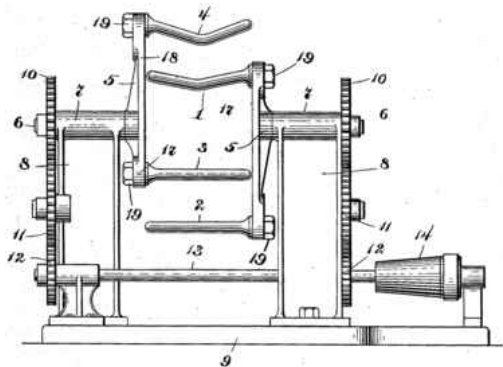

Hildreth was not pleased by this but bought the patent for \$75,000 (about two million of today's dollars).

# some patents have beautiful diagrams

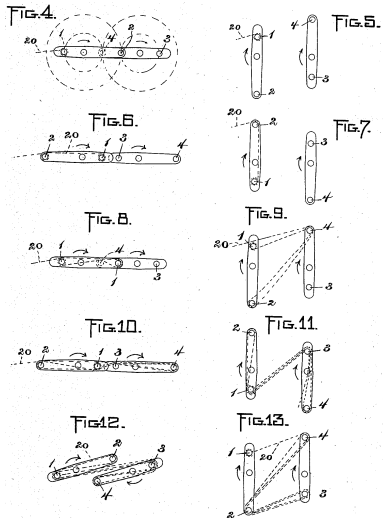

Thibodeau (1903)

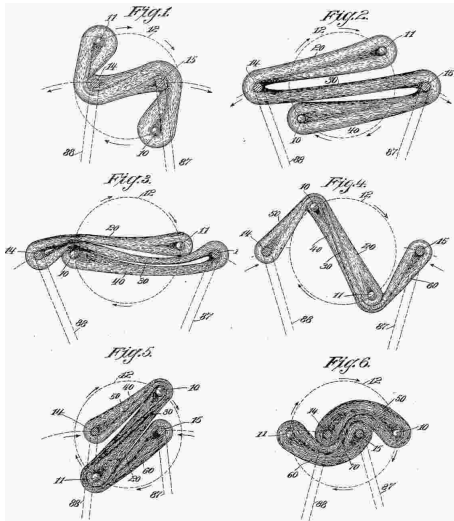

Richards (1905)



So many concurrent patents were filed that lawsuits ensued for more than a decade. Shockingly, the taffy patent wars went all the way to the **US Supreme Court**. The opinion of the Court was delivered by **Chief Justice William Howard Taft** (*Hildreth v. Mastoras*, 1921):

*The machine shown in the Firchau patent [has two pins that] pass each other twice during each revolution [...] and move in concentric circles, but do not have the relative in-and-out motion or Figure 8 movement of the Dickinson machine. With only two hooks there could be no lapping of the candy, because there was no third pin to re-engage the candy while it was held between the other two pins. The movement of the two pins in concentric circles might stretch it somewhat and stir it, **but it would not pull it in the sense of the art.***

The Supreme Court opinion displays the fundamental insight that at least three prongs are required to produce some sort of rapid growth.

# the quest for the Golden ratio



Is it possible to build a device that realizes the **simplest taffy puller**, with growth  $\phi^2$ ?

The problem is that each prong **moves in a Figure-eight!** This is hard to do mechanically.

After some digging, found the patent of Nitz (1918):

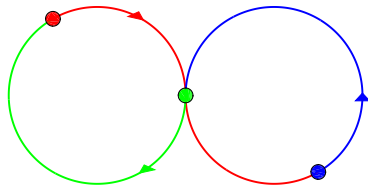
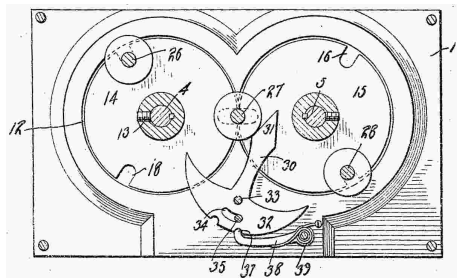

## the quest for the Golden ratio (2)



There is actually an earlier 4-pronged design by Thibodeau (1904) which has  $(\text{Golden ratio})^2$  growth:

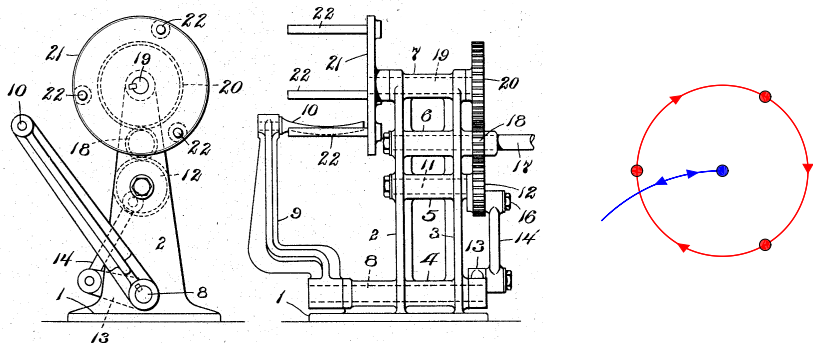

Since it uses four prongs to get a quadratic growth, the map must involve a **branched cover of the torus** by a theorem of Franks & Rykken (1999). (The same happens for the 4- vs 3-pronged 'standard' taffy pullers.)

# the quest for the Golden ratio (3)

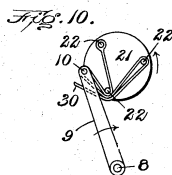
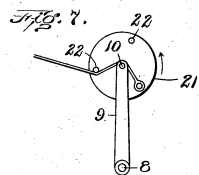
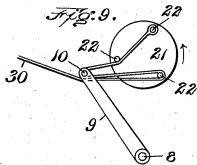
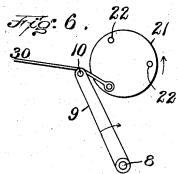
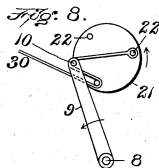
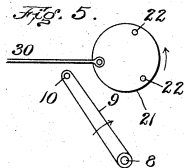

Thibodeau (1904) once again gives very nice diagrams for the action of his taffy puller.

(He has at least 5 patents for taffy pullers.)



A few designs are based on 'planetary' gears, such as McCarthy (1916):

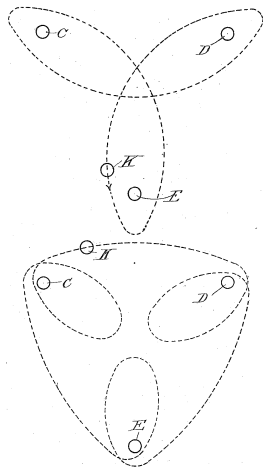
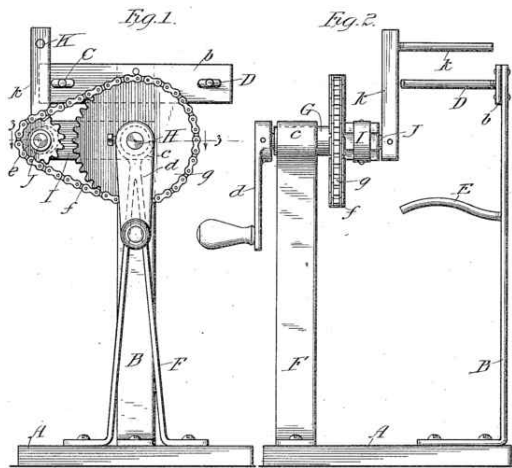

# the mixograph



A modern planetary design is the **mixograph**, a device for measuring the properties of dough:

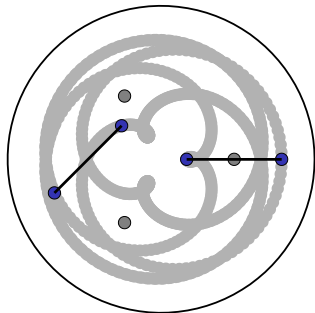

play movie

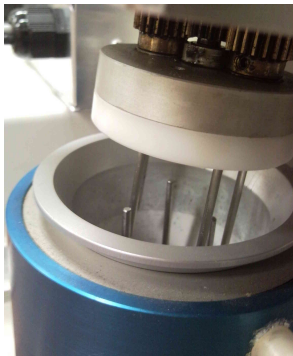

[Department of Food Science, University of Wisconsin. Photos by J-LT.]



The mixograph measures the resistance of the dough to the pin motion.

This is graphed to determine properties of the dough, such as water absorption and 'peak time.'

# the mixograph as a braid



Encode the topological information as a sequence of **generators of the Artin braid group  $B_n$** .

Equivalent to the 7-braid

$$\sigma_3 \sigma_2 \sigma_3 \sigma_5 \sigma_6^{-1} \sigma_2 \sigma_3 \sigma_4 \sigma_3 \sigma_1^{-1} \sigma_2^{-1} \sigma_5$$

We feed this braid to the **Bestvina–Handel algorithm**, which determines the **Thurston type** of the braid (**pseudo-Anosov**) and finds the **growth** as the largest root of

$$x^8 - 4x^7 - x^6 + 4x^4 - x^2 - 4x + 1$$

$$\simeq 4.186$$

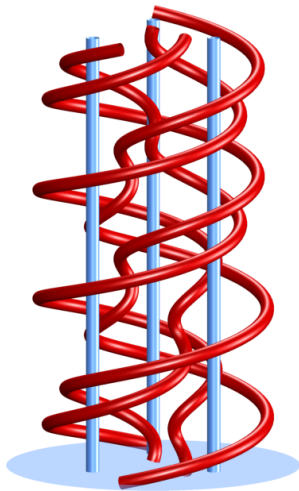

As part of an optimization procedure, we (Finn & Thiffeault, 2011) designed a family of planetary mixers with **silver ratio** expansion:

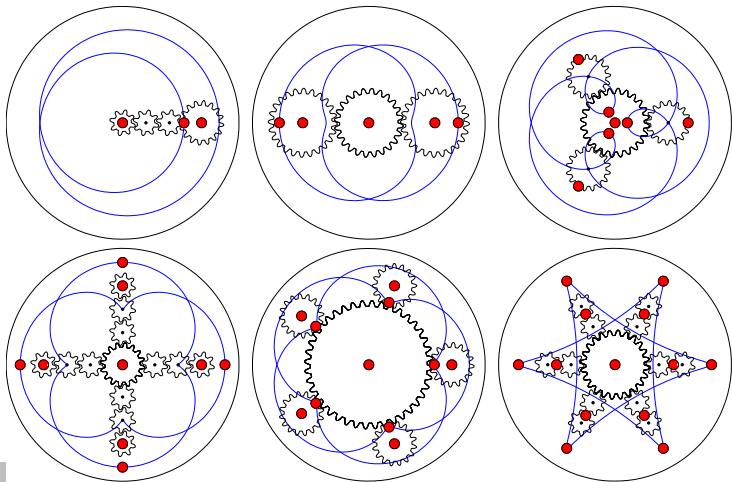

play movie



play movie

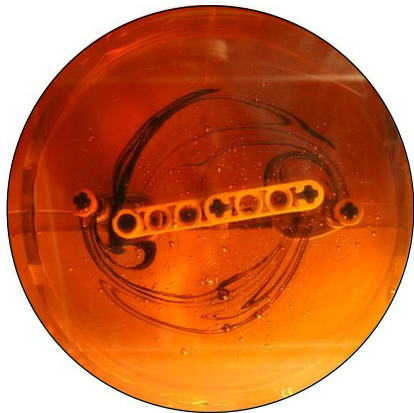

play movie

[See Finn, M. D. & Thiffeault, J.-L. (2011). *SIAM Rev.* **53** (4), 723–743 for proofs, heavily influenced by work on  $\pi_1$ -stirrers of Boyland, P. L. & Harrington, J. (2011). *Algeb. Geom. Topology*, **11** (4), 2265–2296.]

There remains many patents that I call 'exotic' which use nonstandard motions: such as Jenner (1905):

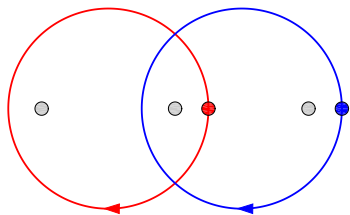
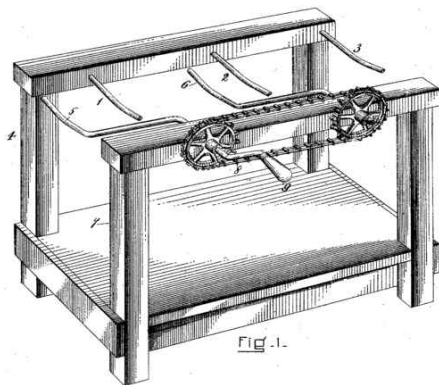



## exotic designs (2)



Shean & Schmelz (1914):

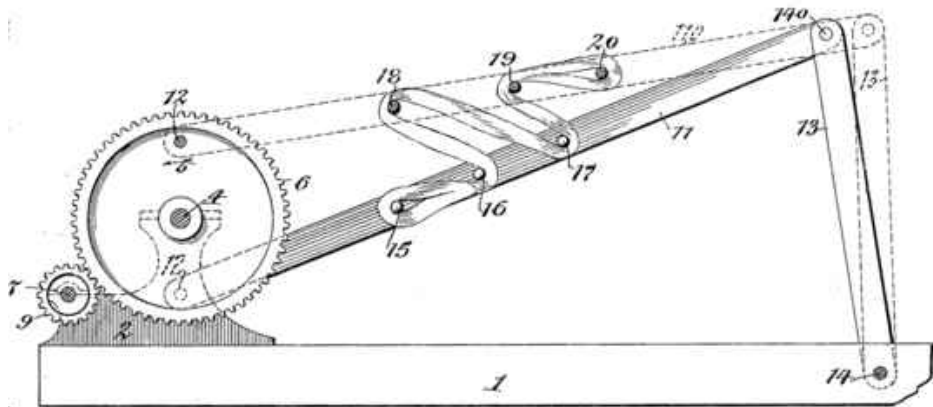

# exotic designs (3)



My personal favorite, McCarthy & Wilson (1915):

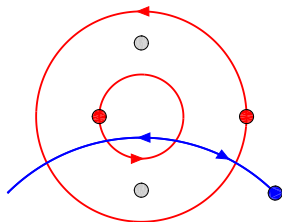
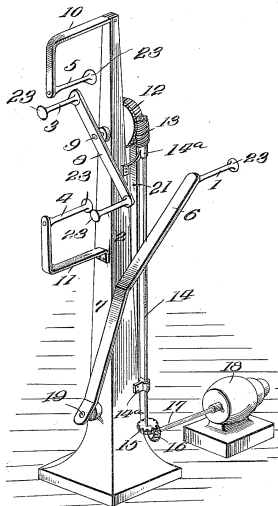

# let's try our hand at this



6-pronged design with Alex Flanagan:

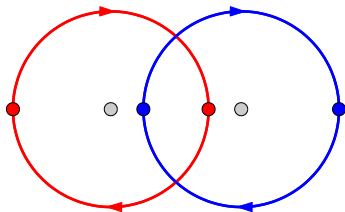
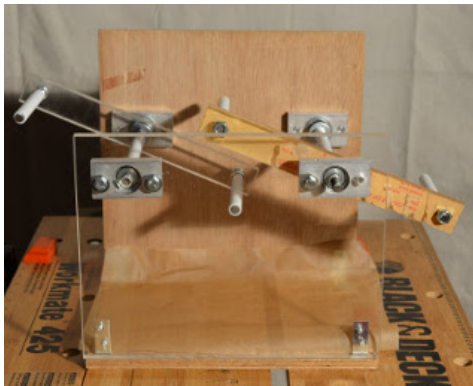

The software tools allow us to rapidly try designs. This one is simple and has huge growth (13.9 vs 5.8 for the standard pullers).

# making taffy is hard



Early efforts yielded mixed results: . . . but eventually we got better at it

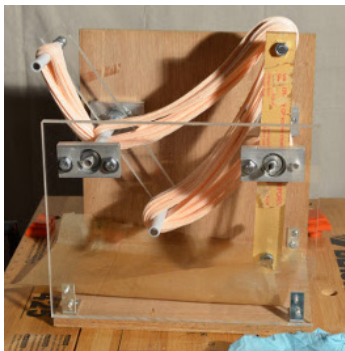
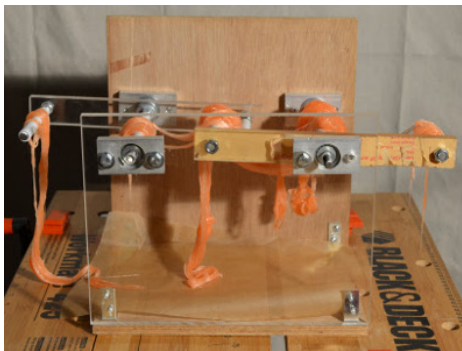

play movie

(BTW: The physics of candy making is fascinating. . .)

The six prongs are fixed points of a hyperelliptic involution of a genus-two surface:

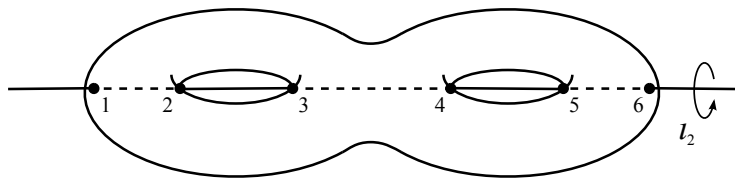

[See Thiffeault, J.-L. (2018). *Math. Intelligencer*, **40** (1), 26–35. arXiv:1608.00152.]

# a cut-up genus-two surface



Two tori are glued to make the genus-two surface:

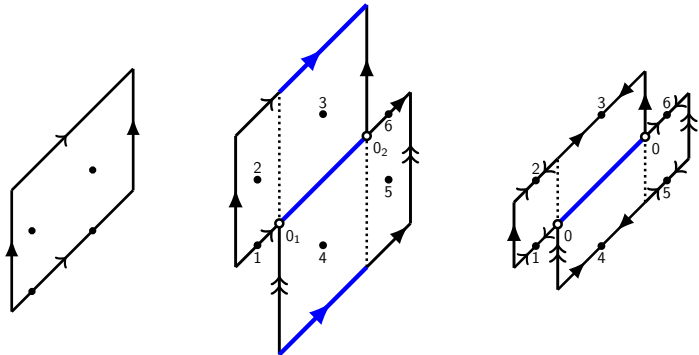

A quotient by the involution then gives a sphere with 6 distinguished points.

# map on a genus-two surface

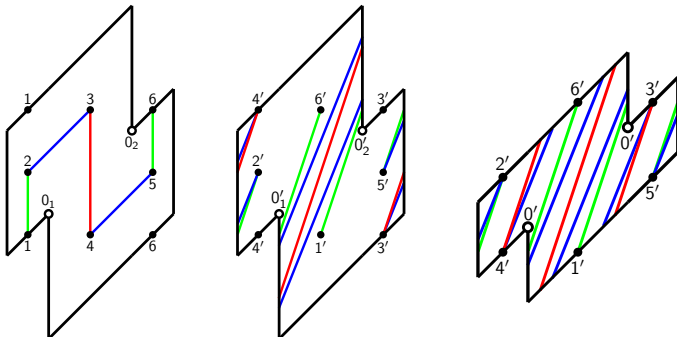

$$\phi(x) = \begin{pmatrix} -1 & -1 \\ -2 & -3 \end{pmatrix} \cdot x$$

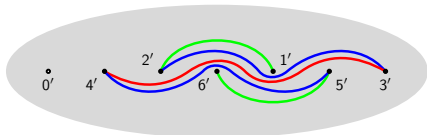
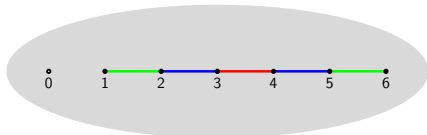



- My real interest is in fluid mixing, in particular of viscous substances.
- The taffy pullers illustrate that mixing is a **combinatorial process**, akin to **shuffling**.
- The taffy designs also pop up in 'serious' **chemical mixers**.
- The topological dynamics methods pioneered by Thurston allows us to understand these prong motions in great detail.
- For example, in addition to the growth, there is a **measure** that tells us how taffy is distributed on the prongs.
- **pseudo-Anosov maps** themselves are still the subject of intense study. The taffy pullers provide a battery of nice examples.





- Allshouse, M. R. & Thiffeault, J.-L. (2012). *Physica D*, **241** (2), 95–105.
- Bestvina, M. & Handel, M. (1995). *Topology*, **34** (1), 109–140.
- Binder, B. J. & Cox, S. M. (2008). *Fluid Dyn. Res.* **40**, 34–44.
- Boyland, P. L., Aref, H., & Stremler, M. A. (2000). *J. Fluid Mech.* **403**, 277–304.
- Boyland, P. L. & Harrington, J. (2011). *Algeb. Geom. Topology*, **11** (4), 2265–2296.
- Boyland, P. L., Stremler, M. A., & Aref, H. (2003). *Physica D*, **175**, 69–95.
- D'Alessandro, D., Dahleh, M., & Mezić, I. (1999). *IEEE Transactions on Automatic Control*, **44** (10), 1852–1863.
- Dickinson, H. M. (1906).
- Finn, M. D. & Thiffeault, J.-L. (2011). *SIAM Rev.* **53** (4), 723–743.
- Firchau, P. J. G. (1893).
- Franks, J. & Rykken, E. (1999). *Proc. Amer. Math. Soc.* **127**, 2183–2192.
- Gouillart, E., Finn, M. D., & Thiffeault, J.-L. (2006). *Phys. Rev. E*, **73**, 036311.
- Halbert, J. T. & Yorke, J. A. (2014). *Topology Proceedings*, **44**, 257–284.
- Handel, M. (1985). *Ergod. Th. Dynam. Sys.* **8**, 373–377.
- Jenner, E. J. (1905).



- Kobayashi, T. & Umeda, S. (2007). In: *Proceedings of the International Workshop on Knot Theory for Scientific Objects, Osaka, Japan* pp. 97–109, Osaka, Japan: Osaka Municipal Universities Press.
- Lin, Z., Doering, C. R., & Thiffeault, J.-L. (2011). *J. Fluid Mech.* **675**, 465–476.
- MacKay, R. S. (2001). *Philos. Trans. Royal Soc. Lond. A*, **359**, 1479–1496.
- Mathew, G., Mezić, I., & Petzold, L. (2005). *Physica D*, **211** (1-2), 23–46.
- McCarthy, E. F. (1916).
- McCarthy, E. F. & Wilson, E. W. (1915).
- Moussafir, J.-O. (2006). *Func. Anal. and Other Math.* **1** (1), 37–46.
- Nitz, C. G. W. (1918).
- Richards, F. H. (1905).
- Robinson, E. M. & Deiter, J. H. (1908).
- Shean, G. C. C. & Schmelz, L. (1914).
- Stremler, M. A. & Chen, J. (2007). *Phys. Fluids*, **19**, 103602.
- Thibodeau, C. (1903).
- Thibodeau, C. (1904).
- Thiffeault, J.-L. (2005). *Phys. Rev. Lett.* **94** (8), 084502.
- Thiffeault, J.-L. (2012). *Nonlinearity*, **25** (2), R1–R44.



- Thiffeault, J.-L. (2018). *Math. Intelligencer*, **40** (1), 26–35. arXiv:1608.00152.
- Thiffeault, J.-L. & Finn, M. D. (2006). *Philos. Trans. Royal Soc. Lond. A*, **364**, 3251–3266.
- Thiffeault, J.-L., Finn, M. D., Gouillart, E., & Hall, T. (2008). *Chaos*, **18**, 033123.
- Thurston, W. P. (1988). *Bull. Am. Math. Soc.* **19**, 417–431.
- Tumasz, S. E. & Thiffeault, J.-L. (2013). *J. Nonlinear Sci.* **13** (3), 511–524.