

The combinatorics of open covers (II)

Winfried Just¹, Arnold W. Miller, Marion Scheepers²,
and Paul J. Szeptycki

Abstract

We continue to investigate various diagonalization properties for sequences of open covers of separable metrizable spaces introduced in Part I. These properties generalize classical ones of Rothberger, Menger, Hurewicz, and Gerlits-Nagy. In particular, we show that most of the properties introduced in Part I are indeed distinct. We characterize two of the new properties by showing that they are equivalent to saying all finite powers have one of the classical properties above (Rothberger property in one case and in the Menger property in other). We consider for each property the smallest cardinality of metric space which fails to have that property. In each case this cardinal turns out to equal another well-known cardinal less than the continuum. We also disprove (in ZFC) a conjecture of Hurewicz which is analogous to the Borel conjecture. Finally, we answer several questions from Part I concerning partition properties of covers. ³

Introduction

Many topological properties of spaces have been defined or characterized in terms of the properties of open coverings of these spaces. Popular among such properties are the properties introduced by Gerlits and Nagy [6], Hurewicz [7], Menger [12] and Rothberger [14]. These are all defined in terms of the possibility of extracting from a given sequence of open covers of some sort, an open cover of some (possibly different) sort.

¹partially supported by NSF grant DMS-9312363

²partially supported by NSF grant DMS-95-05375

³AMS Classification: 03E05 04A20 54D20

Key words: Rothberger property C'' , Gerlits-Nagy property γ -sets, Hurewicz property, Menger property, γ -cover, ω -cover, Sierpiński set, Lusin set.

Appears in *Topology and its applications*, 73(1996), 241-266.

In Scheepers [16] it was shown that when one systematically studies the definitions involved and inquires whether other natural variations of the defining procedures produce any new classes of sets which have mathematically interesting properties, an aesthetically pleasing picture emerges. In [16] the basic implications were established. It was left open whether these were the only implications.

Let X be a topological space. By a “cover” for X we always mean “countable open cover”. Since we are primarily interested in separable metrizable (and hence Lindelöf) spaces, the restriction to countable covers does not lead to a loss of generality. A cover \mathcal{U} of X is said to be

1. *large* if for each x in X the set $\{U \in \mathcal{U} : x \in U\}$ is infinite;
2. *an ω -cover* if X is not in \mathcal{U} and for each finite subset F of X , there is a set $U \in \mathcal{U}$ such that $F \subset U$;
3. *a γ -cover* if it is infinite and for each x in X the set $\{U \in \mathcal{U} : x \notin U\}$ is finite.

We shall use the symbols \mathcal{O} , Λ , Ω and Γ to denote the collections of all open, large, ω and γ -covers respectively, of X . Let \mathcal{A} and \mathcal{B} each be one of these four classes. We consider the following three “procedures”, S_1 , S_{fin} and U_{fin} , for obtaining covers in \mathcal{B} from covers in \mathcal{A} :

1. $S_1(\mathcal{A}, \mathcal{B})$: For a sequence $(\mathcal{U}_n : n = 1, 2, 3, \dots)$ of elements of \mathcal{A} , select for each n a set $U_n \in \mathcal{U}_n$ such that $\{U_n : n = 1, 2, 3, \dots\}$ is a member of \mathcal{B} ;
2. $S_{fin}(\mathcal{A}, \mathcal{B})$: For a sequence $(\mathcal{U}_n : n = 1, 2, 3, \dots)$ of elements of \mathcal{A} , select for each n a finite set $\mathcal{V}_n \subset \mathcal{U}_n$ such that $\bigcup_{n=1}^{\infty} \mathcal{V}_n$ is an element of \mathcal{B} ;
3. $U_{fin}(\mathcal{A}, \mathcal{B})$: For a sequence $(\mathcal{U}_n : n = 1, 2, 3, \dots)$ of elements of \mathcal{A} , select for each n a finite set $\mathcal{V}_n \subset \mathcal{U}_n$ such that $\{\bigcup \mathcal{V}_n : n = 1, 2, 3, \dots\}$ is a member of \mathcal{B} or⁴ there exists an n such that $\bigcup \mathcal{V}_n = X$.

For G one of these three procedures, let us say that a space has property $G(\mathcal{A}, \mathcal{B})$ if for every sequence of elements of \mathcal{A} , one can obtain an element of \mathcal{B} by means of procedure G . Letting \mathcal{A} and \mathcal{B} range over the set $\{\mathcal{O}, \Lambda, \Omega, \Gamma\}$,

⁴This is similar to the $*$ convention of [16].

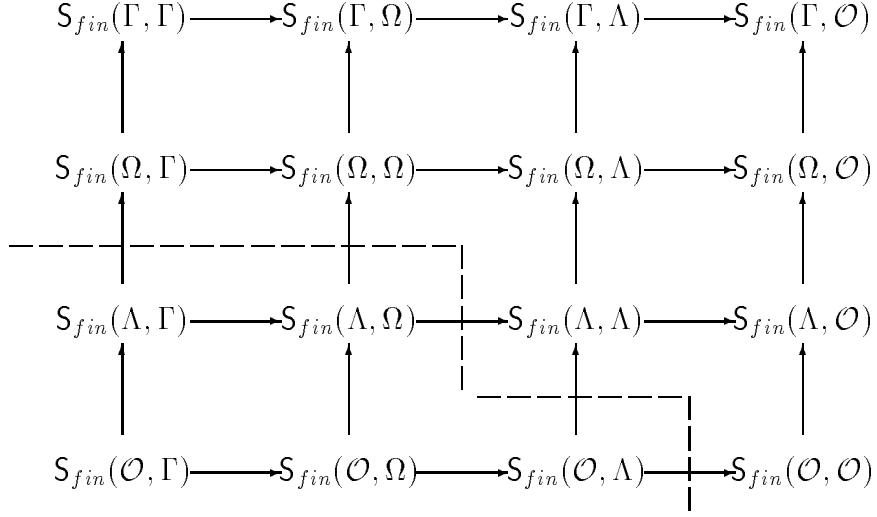

Figure 1: Basic diagram for S_{fin}

we see that for each G there are potentially sixteen classes of spaces of the form $G(\mathcal{A}, \mathcal{B})$. Each of our properties is monotone decreasing in the first coordinate and increasing in the second, hence we get the following diagram (see figure 1) for $G = S_{fin}$.

It also is easily checked that $S_{fin}(\Lambda, \Omega)$ and $S_{fin}(\mathcal{O}, \Lambda)$ are impossible for nontrivial X . Hence the five classes in the lower left corner are eliminated. The same follows for the stronger property S_1 . In the case of U_{fin} note that for any class of covers \mathcal{B} , $U_{fin}(\mathcal{O}, \mathcal{B})$ is equivalent to $U_{fin}(\Gamma, \mathcal{B})$ because given an open cover $\{U_n : n \in \omega\}$ we may replace it by the γ -cover, $\{\cup_{i < n} U_i : n \in \omega\}$. This means the diagram of U_{fin} reduces to any of its rows. Now clearly S_1 implies S_{fin} . Also it is clear that $S_{fin}(\Gamma, \mathcal{A}) \rightarrow U_{fin}(\Gamma, \mathcal{A})$ for $\mathcal{A} = \Gamma, \Omega, \mathcal{O}$. The implication

$$S_{fin}(\Gamma, \Lambda) \rightarrow U_{fin}(\Gamma, \Lambda)$$

is also true, but takes a little thought since when we take finite unions we might not get distinct sets. To prove it, assume \mathcal{U}_n are γ -covers of X with no finite subcover. Applying S_{fin} we get a sequence of finite $\mathcal{V}_n \subseteq \mathcal{U}_n$ such that for any x there exists infinitely many n such that $x \in \cup \mathcal{V}_n$. But since

the \mathcal{U}_m 's have no finite subcover we can inductively choose a finite \mathcal{W}_n with

$$\mathcal{V}_n \subseteq \mathcal{W}_n \subseteq \mathcal{U}_n$$

and $\cup \mathcal{W}_n \neq \cup \mathcal{W}_m$ for any $m < n$. Hence $\cup \{\mathcal{W}_n : n = 1, 2, 3, \dots\}$ is a large cover of X .

In the three-dimensional diagram of figure 2 the double lines indicate that the two properties are equivalent. The proof of these equivalences can be found in either Scheepers [16] or section 1 of this paper. After removing duplications we obtain figure 3.

For this diagram, we have provided four examples $\{C, S, H, L\}$ which show that practically no other implications can hold. C is the Cantor set (2^ω), S is a special Sierpiński set such the $S + S$ can be mapped continuously onto the irrationals, L is a special Lusin set such that $L + L$ can be mapped continuously onto the irrationals, and H is a generic Lusin set. Thus the only remaining problems are:

Problem 1 *Is $\mathsf{U}_{fin}(\Gamma, \Omega) = \mathsf{S}_{fin}(\Gamma, \Omega)$?*

Problem 2 *And if not, does $\mathsf{U}_{fin}(\Gamma, \Gamma)$ imply $\mathsf{S}_{fin}(\Gamma, \Omega)$?*

All of our examples are subsets of the real line, but only one of them (the Cantor set) is a ZFC example. Thus, the following problem arises:

Problem 3 *Are there ZFC examples of (Lindelöf) topological spaces which show that none of the arrows in figure 3 can even be consistently reversed?*

The paper is organized as follows:

In section 1, we prove the equivalences of our properties indicated in figure 2. We prove that $\mathsf{S}_1(\Gamma, \Gamma) = \mathsf{S}_{fin}(\Gamma, \Gamma)$ and $\mathsf{S}_{fin}(\Lambda, \Lambda) = \mathsf{S}_{fin}(\Gamma, \Lambda)$. The other equivalences are either trivial or were proved in Scheepers [16]. In section 2 we present the four examples C,S,H,L indicated in figure 3. In section 3 we study the preservation of these families under the taking of finite powers and other operations.

In section 4 we study for each of these eleven families the cardinal

$non(P):=$

the minimum cardinality of a set of reals that fails to have property P .

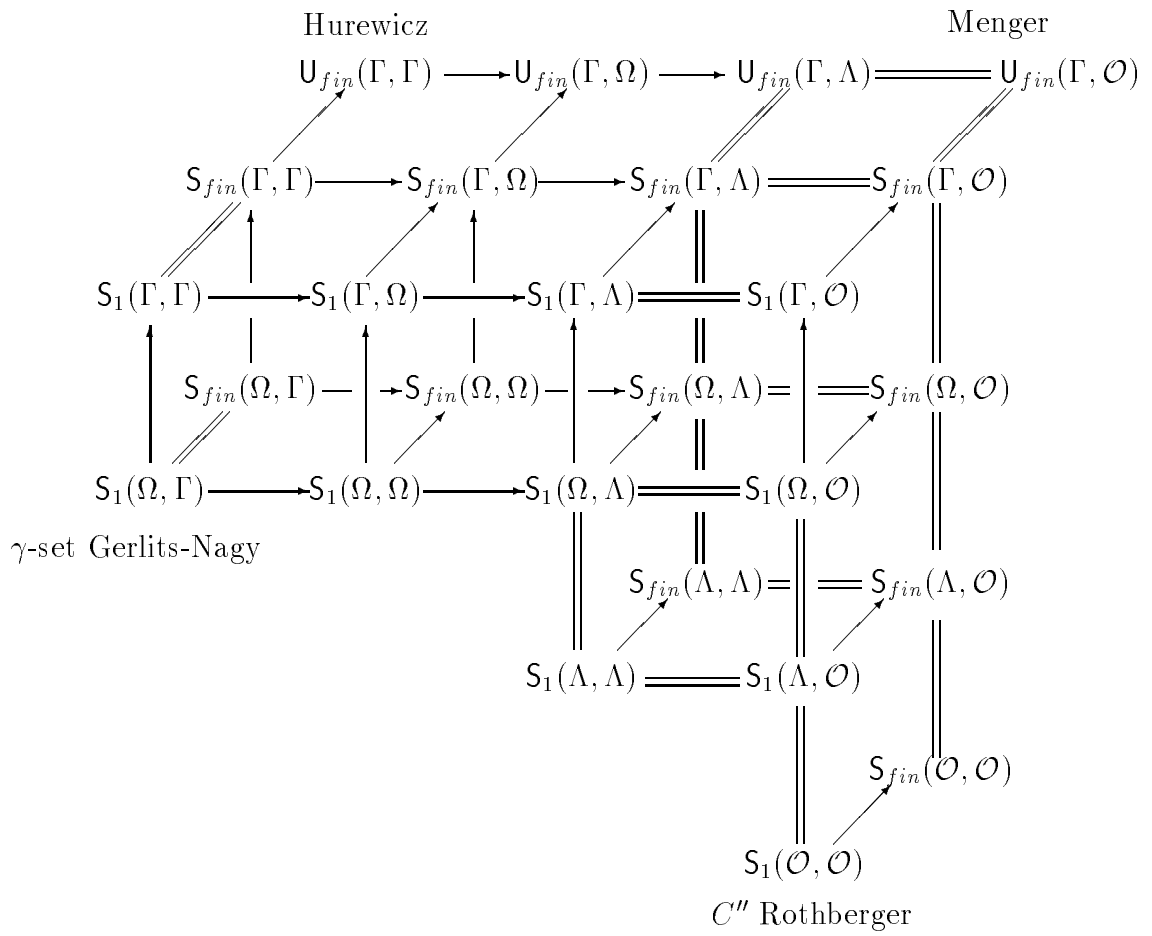

Figure 2: Full 3d diagram

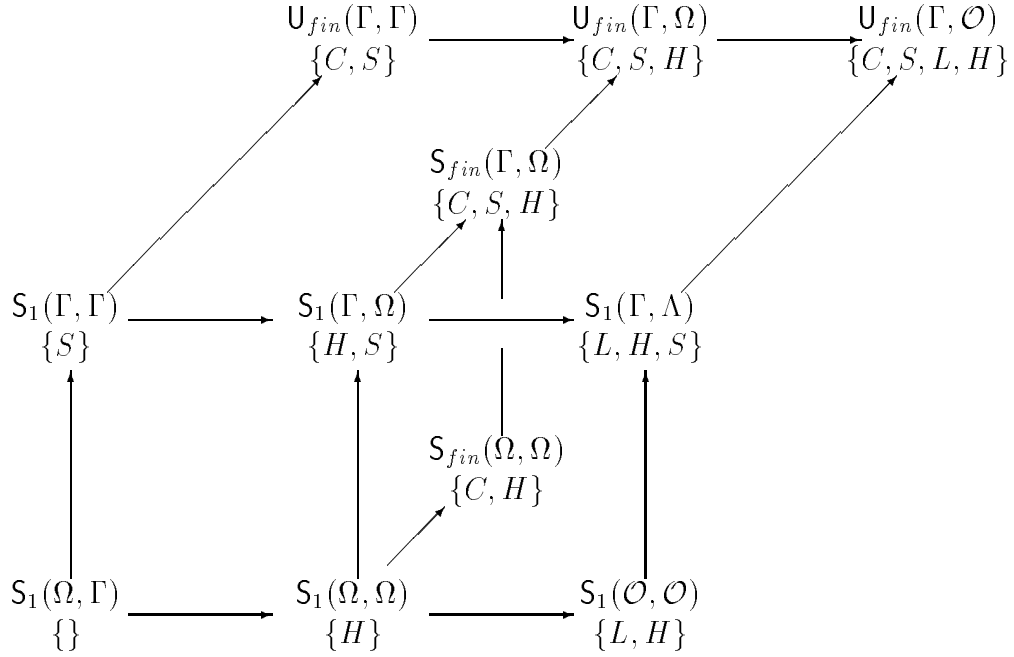

Figure 3: After removing equivalent classes

We show that each is equal to either \mathfrak{b} , \mathfrak{d} , \mathfrak{p} , or the covering number of the meager ideal $\text{cov}(\mathcal{M})$. We also show that $\mathfrak{r} = \text{non}(\text{Split}(\Lambda, \Lambda))$ and $\mathfrak{u} = \text{non}(\text{Split}(\Omega, \Omega))$. ($\text{Split}(\mathcal{A}, \mathcal{B})$ holds iff every infinite cover from \mathcal{A} can be split into two covers from \mathcal{B}).

In section 5 we give a ZFC counterexample to a conjecture of Hurewicz by showing that there exists an uncountable set of reals in $\mathbf{U}_{fin}(\Gamma, \Gamma)$ which is not σ -compact. We also show the any $\mathbf{U}_{fin}(\Gamma, \Gamma)$ set which does not contain a perfect set is perfectly meager.

In section 6 we consider other properties from Scheepers [16] and settle some questions about Ramsey-like properties of covers that were left open in [16]. We show that $\mathbf{S}_1(\Omega, \Omega)$ implies $Q(\Omega, \Omega)$ and hence

$$\mathbf{S}_1(\Omega, \Omega) = \mathbf{P}(\Omega, \Omega) + \mathbf{Q}(\Omega, \Omega).$$

We also show that $\Omega \rightarrow [\Omega]_2^2$ is equivalent to $\mathbf{S}_{fin}(\Omega, \Omega)$ (see section 6 for the definitions).

1 Equivalences

In this section we show $\mathcal{S}_1(\Gamma, \Gamma) = \mathcal{S}_{fin}(\Gamma, \Gamma)$ and $\mathcal{S}_{fin}(\Gamma, \Lambda) = \mathcal{S}_{fin}(\Lambda, \Lambda)$.

The equivalence $\mathcal{S}_1(\Omega, \Gamma)$ with the γ -set property (every ω -cover contains a γ -cover) was shown by Gerlits and Nagy [6]. But it is easy to see that $\mathcal{S}_{fin}(\Omega, \Gamma)$ implies the γ -set property and hence $\mathcal{S}_1(\Omega, \Gamma) = \mathcal{S}_{fin}(\Omega, \Gamma)$. In Scheepers [16] (Cor 6) it was shown that $\mathcal{S}_1(\Gamma, \Lambda) = \mathcal{S}_1(\Gamma, \mathcal{O})$.

All of the other equivalences are either to the Rothberger property C'' or the Menger property. For the Menger property, in Scheepers [16] (Cor 5) it was shown that $\mathcal{S}_{fin}(\Gamma, \Lambda) = \mathcal{U}_{fin}(\Gamma, \mathcal{O})$. $\mathcal{S}_{fin}(\Gamma, \Lambda) = \mathcal{S}_{fin}(\Lambda, \Lambda)$ by Theorem 1.2 and note also that $\mathcal{S}_{fin}(\mathcal{O}, \mathcal{O})$ easily follows from $\mathcal{U}_{fin}(\Gamma, \mathcal{O})$ and hence all nine classes (see figure 2) are equivalent to the Menger property. In [16] (Thm 17) it was shown that all five classes (see figure 2) are equivalent to the Rothberger property (C'').

Theorem 1.1 $\mathcal{S}_1(\Gamma, \Gamma) = \mathcal{S}_{fin}(\Gamma, \Gamma)$.

Proof:

Note that the class $\mathcal{S}_1(\Gamma, \Gamma)$ is contained in the class $\mathcal{S}_{fin}(\Gamma, \Gamma)$. The difficulty with showing that these two classes are in fact equal is as follows: when we are allowed to choose finitely many elements per γ -cover, we are allowed to also pick no elements; for $\mathcal{S}_1(\Gamma, \Gamma)$ we are required to choose an element per γ -cover.

Let X be a space which has property $\mathcal{S}_{fin}(\Gamma, \Gamma)$, and for each n let \mathcal{U}_n be a γ -cover of X , enumerated bijectively as $(U_1^n, U_2^n, U_3^n, \dots)$.

For each n define \mathcal{V}_n to be $\{V_1^n, V_2^n, V_3^n, \dots\}$, where

$$V_k^n = U_k^1 \cap U_k^2 \cap U_k^3 \cap \dots \cap U_k^n.$$

For each n , \mathcal{V}_n is a γ -cover: For fix n . For each x , and for each $i \in \{1, \dots, n\}$ there exists an N_i such that x is in U_m^i for all $m > N_i$. But then x is in V_m^n for all $m > \max\{N_i : i = 1, \dots, n\}$.

Now apply $\mathcal{S}_{fin}(\Gamma, \Gamma)$ to $(\mathcal{V}_n : n = 1, 2, \dots)$. We get a sequence

$$(\mathcal{W}_n : n \in \omega)$$

such that \mathcal{W}_n is a finite subset of \mathcal{V}_n for each n , and such that $\bigcup_{n=1}^{\infty} \mathcal{W}_n$ is a γ -cover of X .

Choose an increasing sequence $n_1 < n_2 < \dots < n_k < \dots$ such that for each j , $\mathcal{W}_{n_j} \setminus \cup_{i < j} \mathcal{W}_{n_i}$ is nonempty. This is possible because each \mathcal{W}_n is finite, while the union of these sets, being a γ -cover of X , is infinite. For each j , choose m_j such that $V_{m_j}^{n_j}$ is an element of $\mathcal{W}_{n_j} \setminus \cup_{i < j} \mathcal{W}_{n_i}$. Then $\{V_{m_k}^{n_k} : k = 1, 2, \dots\}$ is a γ -cover of X .

For each n in $(n_k, n_{k+1}]$ we define $U_n = U_{n_{k+1}}^n$. Then $\{U_n : n = 1, 2, \dots\}$ is a γ cover of X .

■

Theorem 1.2 $S_{fin}(\Gamma, \Lambda) = S_{fin}(\Lambda, \Lambda)$.

Proof:

Since $\Gamma \subseteq \Lambda$, it is clear that $S_{fin}(\Lambda, \Lambda)$ implies $S_{fin}(\Gamma, \Lambda)$. We prove the other implication.

Assume $S_{fin}(\Gamma, \Lambda)$ and let $(\mathcal{U}_n : n \in \omega)$ be a sequence of large covers of X . Without loss of generality we may assume that for every finite $F \subseteq \cup_{n \in \omega} \mathcal{U}_n$ we have that $\mathcal{U}_k \cap F = \emptyset$ for all but finitely many k . (This can be accomplished by throwing out finitely many elements from each \mathcal{U}_n .)

For each n enumerate \mathcal{U}_n bijectively as $(U_k^n : k \in \omega)$, and define

$$V_m^n = \bigcup \{U_i^n : i < m\}.$$

Since each $\mathcal{V}_n = (V_m^n : m \in \omega)$ is a nondecreasing open cover of X , either there exists m_n such that $V_{m_n}^n = X$ or \mathcal{V}_n is a γ -cover. So there must be an infinite A for which one or the other always occurs. Suppose \mathcal{V}_n is a γ -cover for every $n \in A$. Apply $S_{fin}(\Gamma, \Lambda)$ to obtain \mathcal{W}_n a finite subset of \mathcal{V}_n such that $\bigcup \{\mathcal{W}_n : n \in A\}$ is a large cover of X . Let \mathcal{P}_n be a finite subset of \mathcal{U}_n such that every element of \mathcal{W}_n is a union of elements of \mathcal{P}_n . Since \mathcal{P}_n is disjoint from all but finitely many of the \mathcal{U}_k , it follows that $\bigcup \{\mathcal{P}_n : n \in A\}$ is a large cover of X . In the case that $V_{m_n}^n = X$ for every $n \in A$ just take $\mathcal{P}_n = \{U_i^n : i < m_n\}$ and the same argument works.

■

2 Examples

The Cantor set \mathbf{C}

We shall check that every σ -compact space (the union of countably many compact sets) belongs to $\mathbf{U}_{fin}(\Gamma, \Gamma)$ and $\mathbf{S}_{fin}(\Omega, \Omega)$. We also show that the Cantor set, 2^ω , is not in the class $\mathbf{S}_1(\Gamma, \Lambda)$.

For the sake of conciseness, let us introduce the following notion. An open cover \mathcal{U} of a topological space X is a k -cover iff there is for every k -element subset of X an element of \mathcal{U} which covers that set.

Lemma 2.1 *Let k be a positive integer. Every ω -cover of a compact space contains a finite subset which is a k -cover for the space.*

Proof:

Let \mathcal{U} be an ω -cover of the compact space X and let k be a positive integer. Then the set $\mathcal{V} = \{U^k : U \in \mathcal{U}\}$ of k -th powers of elements of \mathcal{U} is a collection of open subsets of X^k , and it is a cover of X^k since \mathcal{U} is an ω -cover of X . Since X is compact, so is X^k . Thus there is a finite subset of \mathcal{V} which covers X^k , say $\{U_1^k, \dots, U_n^k\}$. But then $\{U_1, \dots, U_n\}$ is a k -cover of X .

■

Theorem 2.2 *Every σ -compact topological space is a member of both the class $\mathbf{S}_{fin}(\Omega, \Omega)$ and $\mathbf{U}_{fin}(\Gamma, \Gamma)$.*

Proof:

Let X be a σ -compact space, and write $X = \cup_{n \in \omega} K_n$ where

$$K_0 \subseteq K_1 \subseteq \dots \subseteq K_n \subseteq$$

is a sequence of compact subsets of X .

Let $(\mathcal{U}_n : n \in \omega)$ be a sequence of ω -covers of X . For each n apply Lemma 2.1 to the ω -cover \mathcal{U}_n of the space K_n , to find a finite subset \mathcal{V}_n of \mathcal{U}_n which is an n -cover of K_n . Then $\cup_{n \in \omega} \mathcal{V}_n$ is an ω -cover of X . This shows that X has property $\mathbf{S}_{fin}(\Omega, \Omega)$.

Now suppose that $(\mathcal{U}_n : n \in \omega)$ is a sequence of γ -covers of X . Since any infinite subset of a γ -cover is a γ -cover, we may assume that our covers are disjoint. Since each K_n is compact we may choose $\mathcal{V}_n \in [\mathcal{U}_n]^{<\omega}$ so that $K_n \subseteq \cup \mathcal{V}_n$. Either there exists n such that $\cup \mathcal{V}_n = X$ or $\{\cup \mathcal{V}_n : n \in \omega\}$ is

infinite and hence a γ -cover of X . It follows that X has property $\mathbf{U}_{fin}(\Gamma, \Gamma)$.

■

Theorem 2C of [3] shows that if X is not compact, then X^ω is not in the class $\mathbf{S}_{fin}(\mathcal{O}, \mathcal{O})$. For compact X we have the following.

Theorem 2.3 *For every nontrivial compact space X , the product X^ω is not in the class $\mathbf{S}_1(\Gamma, \mathcal{O})$.*

Proof:

If $|X| \geq 2$, then the Cantor set 2^ω embeds as a closed subset of X^ω . Therefore it suffices to prove the theorem for 2^ω . There exists an $\omega \times \omega$ -matrix $(A_n^m : m, n < \omega)$ of closed subsets of the Cantor set such that

1. for each fixed $m \in \omega$ the sets A_n^m for $n < \omega$ are pairwise disjoint and
2. whenever $m_1 < m_2 < \dots < m_k$ and n_1, n_2, \dots, n_k are given, then $A_{n_1}^{m_1} \cap \dots \cap A_{n_k}^{m_k} \neq \emptyset$.

To see that such a matrix exists think of the Cantor set as the homeomorphic space $2^{\omega \times \omega}$ instead.

Let $\langle x_n, n < \omega \rangle$ be a sequence of pairwise distinct elements of 2^ω . Also, for each m , let

$$\pi_m : 2^{\omega \times \omega} \rightarrow 2^\omega$$

be defined so that for each y in $2^{\omega \times \omega}$ and for each m , $\pi_m(y)(n) = y(m, n)$. Then π_m is continuous. We now define our matrix.

For each m and n we define

$$A_n^m = \{y \in 2^{\omega \times \omega} : \pi_m(y) = x_n\}$$

Each row of the matrix is pairwise disjoint since the x_n 's are pairwise distinct. Each entry of the matrix is a closed set since each π_m is continuous. We must still verify property 2. Thus, let $(m_1, n_1), \dots, (m_k, n_k)$ be given such that $m_1 < \dots < m_k$. Let the element y of $2^{\omega \times \omega}$ be defined by $y(m_i, j) = x_{n_i}(j)$ $i \in \omega$ and for each $j \in \omega$. Then y is a member of the set $A_{n_1}^{m_1} \cap \dots \cap A_{n_k}^{m_k}$, whence this intersection is nonempty.

For each m put $\mathcal{U}_m = \{2^\omega \setminus A_n^m : n < \omega\}$. Then by property 1 we see that each \mathcal{U}_m is a γ -cover of 2^ω .

For each m choose a U_m from \mathcal{U}_m . Then $U_m = 2^\omega \setminus A_{n_m}^m$. By the property 2 and the fact that all the A_n^m 's are compact, we see that the intersection $\bigcap_{m < \omega} A_{n_m}^m$ is nonempty. But then $\{U_m : m < \omega\}$ not a cover of $2^{\omega \times \omega}$.

■

It follows from theorems 2.2 and 2.3 that the Cantor set C must lie exactly in those classes indicated in figure 3 in our introduction.

Theorem 2.4 *No uncountable F_σ set of reals is in $S_1(\Gamma, \Gamma)$.*

Proof:

Such a set contains an uncountable compact perfect set. The Cantor set is a continuous image of such perfect sets.

■

The special Lusin set L

Recall that a set L of real numbers is said to be a *Lusin* set iff it is uncountable but its intersection with every first category set of real numbers is countable. Sierpiński [17] showed that assuming CH there exists a Lusin set L such that $L + L$ is the irrationals (see also Miller [13] Thm 8.5).

We will construct similarly a Lusin set $L \subseteq \mathbb{Z}^\omega$ with the property that $L + L = \mathbb{Z}^\omega$. Here \mathbb{Z}^ω is the infinite product of the ring of integers and addition is the usual pointwise addition, i.e, $(x + y)(n) = x(n) + y(n)$. Our construction is based on the following simple fact:

Lemma 2.5 *If X is a comeager subset of \mathbb{Z}^ω , then for every $x \in \mathbb{Z}^\omega$ there are elements a and b of X such that $a + b = x$.*

Proof:

Since multiplication by -1 and translation by x are homeomorphisms, the set

$$x - X = \{x - y : y \in X\}$$

is also comeager. But then $X \cap (x - X)$ is non-empty. Let z be an element of this intersection. Then $z = a$ for some a in X , and $z = x - b$ for some b in X . The Lemma follows.

■

Lemma 2.6 (CH) *There is a Lusin set $L \subseteq \mathbb{Z}^\omega$ such that $L + L = \mathbb{Z}^\omega$.*

Proof:

Let $(M_\alpha : \alpha < \omega_1)$ bijectively list all first category F_σ -subsets of \mathbb{Z}^ω . Let $(r_\alpha : \alpha < \omega_1)$ bijectively list \mathbb{Z}^ω . Using Lemma 2.5, choose elements x_α, y_α from \mathbb{Z}^ω subject to the following rules:

1. For each α , $r_\alpha = x_\alpha + y_\alpha$, and
2. x_α and y_α are not elements of $\cup_{\beta < \alpha} M_\beta \cup \{x_\beta, y_\beta : \beta < \alpha\}$.

Letting L be the set $\{x_\alpha : \alpha < \omega_1\} \cup \{y_\alpha : \alpha < \omega_1\}$ completes the proof.

■

For a proof of the following result see Rothberger [14].

Theorem 2.7 (Rothberger) *Every Lusin set has property $S_1(\mathcal{O}, \mathcal{O}) = C''$.*

Theorem 2.8 *If L is our special Lusin set (i.e., $L + L = \mathbb{Z}^\omega$), then L does not satisfy $\cup_{fin}(\Gamma, \Omega)$.*

Proof:

Let $\{\mathcal{U}_n : n \in \omega\}$ be the sequence of open covers defined by

$$\mathcal{U}_n = \{U_{n,k} : k \in \omega\}$$

where

$$U_{n,k} = \{f \in \mathbb{Z}^\omega : |f(n)| \leq k\}.$$

Then each \mathcal{U}_n is a γ -cover of L . Let $\{\mathcal{V}_n : n \in \omega\}$ be a sequence such that $\mathcal{V}_n \in [\mathcal{U}_n]^{<\omega}$, and let $h \in \omega^\omega$ be such that

$$h(n) > 2 \cdot \max\{k : U_{n,k} \in \mathcal{V}_n\}$$

for all $n \in \omega$. Let $f, g \in L$ be such that $h = f + g$. Then

$$\max\{|f(n)|, |g(n)|\} \geq \frac{1}{2}h(n)$$

for all $n \in \omega$, and hence $\{f, g\} \not\subseteq \cup \mathcal{V}_n$ for any $n \in \omega$.

■

The special Sierpiński set S

A Sierpiński set is an uncountable subset of the real line which has countable intersection with every set of Lebesgue measure zero. In Theorem 7 of Fremlin and Miller [4] it was shown that every Sierpiński set belongs to the class $U_{fin}(\Gamma, \Gamma)$. Sets with the property that every Borel image in the Baire space is bounded were called A_2 -sets in Bartoszyński and Scheepers [1].

Theorem 2.9 *Every Sierpiński set is an A_2 -set.*

Proof:

Let X be a subset of the unit interval, and assume that X is a Sierpiński set. We may assume that X has outer measure one (else, replace it with the set of points in the unit interval which are rational translations of elements of X). Let a Borel function Ψ from X to ${}^\omega\omega$ be given. Extend it to a Borel function Γ from the unit interval to ${}^\omega\omega$.

For each m and n , define $S_n^m = \{x : \Gamma(x)(j) < n \text{ whenever } j \leq m\}$. Then each S_n^m is a Borel set and thus Lebesgue measurable. Moreover, for each m , if $j < k$ then $S_j^m \subseteq S_k^m$, and $[0, 1] = \bigcup_{n=1}^{\infty} S_n^m$.

Choose for each m an n_m such that the measure of $[0, 1] \setminus S_{n_m}^m$ is at most $(\frac{1}{10})^m$. Then the set $S_k = \bigcap_{m \geq k} S_{n_m}^m$ has measure at least $1 - 9 \cdot (\frac{1}{10})^k$. Consequently the set $S = \bigcup_{k=1}^{\infty} S_k$ has measure 1. Then $X \setminus S$ is a countable set. For each x in $X \cap S$, for all but finitely many m , $\Psi(x)(m) < n_m$. For the remaining countable set $X \setminus S$ we can find a single sequence g such that for all m , $n_m < g(m)$, and for each $x \in X \setminus S$, for all but finitely many m , $\Psi(x)(m) < g(m)$. Then g witnesses that $\Psi[X]$ is bounded.

■

Theorem 2.10 *Every A_2 -set (hence every Sierpiński set) belongs to the class $S_1(\Gamma, \Gamma)$.*

Proof:

Let X be an A_2 -set, and let $(\mathcal{U}_n : n \in \omega)$ be a sequence of γ -covers of it. Enumerate each \mathcal{U}_n bijectively as $(U_m^n : m \in \omega)$.

Define a function Ψ from X to ${}^\omega\omega$ so that for each $x \in X$ and for each n ,

$$\Psi(x)(n) = \min\{m : (\forall k \geq m)(x \in U_k^n)\}.$$

Then Ψ is a Borel function. Choose a strictly increasing function g from ω^ω which eventually dominates each element of $\Psi[X]$. Then the sequence $(U_{g(n)}^n : n \in \omega)$ is a γ -cover of X .

■

Clearly no Sierpiński set is of measure zero. Since every $\mathcal{S}_1(\mathcal{O}, \mathcal{O})$ set is of measure zero, X fails to be $\mathcal{S}_1(\mathcal{O}, \mathcal{O})$. Therefore we have established the following theorem:

Theorem 2.11 *If X is a Sierpiński set of reals, then X is $\mathcal{S}_1(\Gamma, \Gamma)$ but not $\mathcal{S}_1(\mathcal{O}, \mathcal{O})$.*

We call a Sierpiński set S special iff $S + S$ is the set of irrationals. (Here we are using ordinary addition in the reals.) Using an argument similar to Lemma 2.6 one can show that assuming CH there exists a special Sierpiński set.

Theorem 2.12 *A special Sierpiński set is not in the class $\mathcal{S}_{fin}(\Omega, \Omega)$.*

Proof:

By Theorem 3.1 all our classes are closed under continuous images. Note that $S + S$ is the continuous image of $S \times S$. Also ω^ω is not in $\mathcal{U}_{fin}(\Gamma, \mathcal{O})$ (see proof of Theorem 2.8). Hence ω^ω is not in $\mathcal{S}_{fin}(\Omega, \Omega)$ and therefore $S \times S$ is not in $\mathcal{S}_{fin}(\Omega, \Omega)$. But by Theorem 3.5 the class $\mathcal{S}_{fin}(\Omega, \Omega)$ is closed under finite products and therefore S is not in the class $\mathcal{S}_{fin}(\Omega, \Omega)$.

■

These results show that the special Sierpiński set (denoted S) is in exactly the classes indicated in figure 3 of the introduction.

The generic Lusin set H

The fact that no Lusin set satisfies $\mathcal{U}_{fin}(\Gamma, \Gamma)$ follows from Theorem 4.3.

Theorem 2.13 (CH) *There exists a Lusin set H which is $\mathcal{S}_1(\Omega, \Omega)$.*

Proof:

To construct an $\mathcal{S}_1(\Omega, \Omega)$ Lusin set in the reals enumerate all countable sequences of countable open families as $\{(\mathcal{U}_n^\beta)_{n < \omega} : \beta < \omega_1\}$. Also enumerate

all dense open subsets of the reals as $(D_\alpha)_{\alpha < \omega_1}$. We construct X recursively as $\{x_\beta : \beta < \omega_1\}$ as follows. At stage α of the construction we have

$$\{x_\beta : \beta < \alpha\} \text{ and } \{(U_n^\beta)_{n < \omega} : \beta < \alpha\}$$

satisfying for each $\beta < \alpha$:

- (i) $x_\beta \in \bigcap \{D_\delta : \delta < \beta\}$,
- (ii) $\{U_n^\beta : n < \omega\}$ is an ω -cover of $\{x_\delta : \delta < \alpha\} \cup \mathbb{Q}$,
- (iii) if $(U_n^\beta)_{n < \omega}$ was a sequence of ω -covers of $\{x_\delta : \delta < \beta\} \cup \mathbb{Q}$, then $U_n^\beta \in \mathcal{U}_n^\beta$ for every n .

To see how to choose x_α and $(U_n^\alpha)_{n < \omega}$ consider the α 'th sequence of open families: if $(\mathcal{U}_n^\alpha)_{n < \omega}$ is a sequence of ω -covers of $\{x_\delta : \delta < \alpha\} \cup \mathbb{Q}$ first extract an ω -cover $(U_n^\alpha)_{n < \omega}$ so that $U_n^\alpha \in \mathcal{U}_n^\alpha$ for each $n < \omega$ (countable sets are $\mathcal{S}_1(\Omega, \Omega)$). If $(\mathcal{U}_n^\alpha)_{n < \omega}$ is not a sequence of ω -covers of $\{x_\delta : \delta < \alpha\} \cup \mathbb{Q}$ let $U_n^\alpha = \mathbb{R}$ for each $n < \omega$.

Enumerate the finite subsets of $\{x_\delta : \delta < \alpha\} \cup \mathbb{Q}$ as $\{A_k : k < \omega\}$. For each k and each $\beta \leq \alpha$ let

$$O_{k,\beta} = \bigcup \{U_n^\beta : A_k \subseteq U_n^\beta\}.$$

Then $O_{k,\beta}$ is dense and open. We choose

$$x_\alpha \in \bigcap_{\delta \leq \alpha} D_\delta \cap \bigcap_{k < \omega, \beta \leq \alpha} O_{k,\beta}$$

different from all x_δ with $\delta < \alpha$. To see that $(U_n^\beta)_{n < \omega}$ is an ω -cover of $\{x_\delta : \delta \leq \alpha\} \cup \mathbb{Q}$ for each $\beta \leq \alpha$ it suffices to show that each $A_k \cup \{x_\alpha\}$ is covered by some U_n^β for some $n < \omega$. But $x_\alpha \in O_{k,\beta}$ implies that there is an n such that $x_\alpha \in U_n^\beta$ and $A_k \subseteq U_n^\beta$. We let $H = \{x_\delta : \delta < \omega_1\} \cup \mathbb{Q}$. To see that H is $\mathcal{S}_1(\Omega, \Omega)$, fix a sequence of ω -covers $(\mathcal{U}_n)_{n < \omega}$. There is an α such that $(\mathcal{U}_n)_{n < \omega} = (\mathcal{U}_n^\alpha)_{n < \omega}$. Then at stage α of the construction we extracted an appropriate ω -cover of $\{x_\delta : \delta \leq \alpha\}$ and inductive hypothesis (ii) assures that it is also an ω -cover of H .

■

The proof of Theorem 2.13 only requires that the covering number of the meager ideal is equal to the continuum ($\text{cov}(\mathcal{M}) = \mathfrak{c}$). This requirement is equivalent to Martin's Axiom for countable posets. Adding Cohen reals over any model yields an $\mathcal{S}_1(\Omega, \Omega)$ Lusin set and hence our name - generic Lusin set.

3 Preservation of the properties.

Each of the properties in the diagram is inherited by closed subsets and continuous images. The preservation theory is more complicated for other topological constructions.

Theorem 3.1 *Let \mathbf{G} be one of \mathbf{S}_1 , \mathbf{S}_{fin} , or \mathbf{U}_{fin} and let \mathcal{A} and \mathcal{B} range over the set $\{\mathcal{O}, \Omega, \Lambda, \Gamma\}$. If X has property $\mathbf{G}(\mathcal{A}, \mathcal{B})$ and C is a closed subset of X , then C has property $\mathbf{G}(\mathcal{A}, \mathcal{B})$. If $f : X \rightarrow Y$ is continuous and onto and X has the property $\mathbf{G}(\mathcal{A}, \mathcal{B})$, then so does Y .*

Proof:

The closure under taking closed subspaces is clear since if \mathcal{U} is a cover of C in one of the classes $\{\mathcal{O}, \Omega, \Lambda, \Gamma\}$ for C , then

$$\mathcal{V} = \{U \cup (X \setminus C) : U \in \mathcal{U}\}$$

is in the same class for X .

To prove the closure under continuous images use that if \mathcal{U} is a cover of Y in one of the classes $\{\mathcal{O}, \Omega, \Lambda, \Gamma\}$ for Y , then

$$\mathcal{V} = \{f^{-1}(U) : U \in \mathcal{U}\}$$

is in the same class for X .

■

Finite powers

We show that the classes $\mathbf{S}_1(\Omega, \Omega)$, $\mathbf{S}_{fin}(\Omega, \Omega)$, and $\mathbf{S}_1(\Omega, \Gamma)$ are the only ones closed under finite powers.

Lemma 3.2 *Let X be a space and let n be a positive integer. If \mathcal{U} is an ω -cover of X , then $\{U^n : U \in \mathcal{U}\}$ is an ω -cover of X^n .*

Proof:

Observe that if F is a finite subset of X^n , then there is a finite subset G of X such that $F \subset G^n$.

■

Lemma 3.3 *Let X be a topological space and let n be a positive integer. If \mathcal{U} is an ω -cover for X^n , then there is an ω -cover \mathcal{V} of X such that the open cover $\{V^n : V \in \mathcal{V}\}$ of X^n refines \mathcal{U} .*

Proof:

Let \mathcal{U} be an ω -cover of X^n . Let F be a finite subset of X . Then F^n is a finite subset of X^n . Since \mathcal{U} is an ω -cover of X^n , choose an open set $U \in \mathcal{U}$ such that $F^n \subset U$. For any n -tuple (x_1, \dots, x_n) in F^n , find for each $i \in \{1, \dots, n\}$ an open set $U_i(x_1, \dots, x_n) \subset X$ such that $x_i \in U_i(x_1, \dots, x_n)$, and $\prod_{i=1}^n U_i(x_1, \dots, x_n) \subset U$. Then, for each x in F , let U_x be the intersection of all the $U_i(x_1, \dots, x_n)$ which have x as an element. Finally, choose V_F to be the set $\cup_{x \in F} U_x$, an open subset of X which contains F , and which has the property that $F^n \subset V_F^n \subset U$. Put

$$\mathcal{V} = \{V_F : F \in [X]^{<\omega}\}.$$

Then \mathcal{V} is as required.

■

While Lemma 3.2 is also true of γ -covers, Lemma 3.3 is not. The latter follows from the proofs of Theorems 3.4 and 3.7.

Theorem 3.4 *Let n be a positive integer. If a space X has property $\mathcal{S}_1(\Omega, \Omega)$, so does X^n .*

Proof:

Let n be a positive integer and let $(\mathcal{U}_m : m = 1, 2, 3, \dots)$ be a sequence of ω -covers of X^n . By Lemma 3.3 for each m , we can choose \mathcal{V}_m an ω -cover of X such that

$$\{V^n : V \in \mathcal{V}_m\}$$

is an ω -cover of X^n which refines \mathcal{U}_m .

Now apply the fact that X is in $\mathcal{S}_1(\Omega, \Omega)$ to select from each \mathcal{V}_m a set V_m such that $\{V_m : m = 1, 2, 3, \dots\}$ is an ω -cover of X . Then, since for each m the set $\{V^n : V \in \mathcal{V}_m\}$ refines \mathcal{U}_m , we see that we can select from each \mathcal{U}_m a set U_m such that $V_m^n \subseteq U_m$. But then the set $\{U_n : n = 1, 2, 3, \dots\}$ is an ω -cover for X .

■

Theorem 3.5 *Let n be a positive integer and let X be a space. If X has property $\mathcal{S}_{fin}(\Omega, \Omega)$, then X^n also has this property.*

Proof:

Let $(\mathcal{U}_m : m = 1, 2, 3, \dots)$ be a sequence of ω -covers of X^n . For each m , choose an ω -cover \mathcal{V}_m of X such that $\{V^n : V \in \mathcal{V}_m\}$ refines \mathcal{U}_m . Now apply the fact that X satisfies $\mathcal{S}_{fin}(\Omega, \Omega)$: For each m we find a finite subset \mathcal{W}_m of \mathcal{V}_m such that the collection $\cup_{m=1}^{\infty} \mathcal{W}_m$ is an ω -cover of X . For each m , choose a finite subset \mathcal{Z}_m of \mathcal{U}_m such that there is for each W in \mathcal{W}_m a Z in \mathcal{Z}_m such that $W^n \subseteq Z$. Then $\cup_{m=1}^{\infty} \mathcal{Z}_m$ is an ω -cover of X^n .

■

Theorem 3.6 *Let n be a positive integer and let X be a space. If X has property $\mathcal{S}_{fin}(\Omega, \Gamma)$, then X^n also has this property.*

Proof:

This is similar to the last two proofs.

■

Theorem 3.7 [CH] *None of the other classes (see figure 3) are closed under finite powers.*

Proof:

Note the examples L and S are such that their sum $L + L$ and $S + S$ are homeomorphic to the irrationals.

The function ϕ from $L \times L$ which assigns to (x, y) the point $\phi(x, y) = x + y$ is continuous. But the space of irrationals does not have property $\mathcal{U}_{fin}(\Gamma, \mathcal{O})$. Since $\mathcal{U}_{fin}(\Gamma, \mathcal{O})$ is closed under continuous images (see Theorem 3.1) $L \times L$ does not have property $\mathcal{U}_{fin}(\Gamma, \mathcal{O})$.

Similarly, $S \times S$ does not have property $\mathcal{U}_{fin}(\Gamma, \mathcal{O})$. So none of the classes containing either one of them is closed under finite powers.

■

We have seen that the inclusion $\mathcal{S}_1(\Omega, \Omega) \subseteq \mathcal{S}_1(\mathcal{O}, \mathcal{O})$ may be proper, e.g. the special Lusin set L is in $\mathcal{S}_1(\mathcal{O}, \mathcal{O})$ but not in $\mathcal{S}_1(\Omega, \Omega)$. The following theorem, which characterizes $\mathcal{S}_1(\Omega, \Omega)$ as a subset of $\mathcal{S}_1(\mathcal{O}, \mathcal{O})$, is due to M. Sakai [15].

Theorem 3.8 *Let X be a space. Then the following are equivalent:*

1. X satisfies $S_1(\Omega, \Omega)$.
2. Every finite power of X satisfies $S_1(\mathcal{O}, \mathcal{O})$ (Rothberger property C''').

The Borel Conjecture, that every strong measure zero set is countable, implies that the two classes $S_1(\Omega, \Omega)$ and $S_1(\mathcal{O}, \mathcal{O})$ coincide. The Borel Conjecture was proved consistent by Laver.

Problem 4 *Is it true that if there is an uncountable set of real numbers which has property $S_1(\Omega, \Omega)$, then there is a set of real numbers which has property $S_1(\mathcal{O}, \mathcal{O})$ but does not have property $S_1(\Omega, \Omega)$?*

We shall now prove the analogue of Theorem 3.8 for $S_{fin}(\mathcal{O}, \mathcal{O})$ and $S_{fin}(\Omega, \Omega)$.

Theorem 3.9 *For a space X the following are equivalent:*

1. Every finite power of X has property $S_{fin}(\mathcal{O}, \mathcal{O})$.
2. X has property $S_{fin}(\Omega, \Omega)$.

Proof:

The implication $2 \Rightarrow 1$: This follows from Theorem 3.5.

We now work on the implication $1 \Rightarrow 2$: Let $(\mathcal{U}_n : n \in \omega)$ be a sequence of ω -covers of X . Let $(Y_k : k \in \omega)$ be a partition of the set of positive integers into infinite sets. For each m and for each k in Y_m , put $\mathcal{V}_k = \{U^m : U \in \mathcal{U}_k\}$. Then for each m , Lemma 3.3 implies that the sequence $(\mathcal{V}_k : k \in Y_m)$ is a sequence of ω -covers of X^m .

Applying 1 for each m , we find for each m a sequence $(\mathcal{W}_k : k \in Y_m)$ such that

- for each $k \in Y_m$, \mathcal{W}_k is a finite subset of \mathcal{U}_k , and
- $\cup_{k \in Y_m} \{U^m : U \in \mathcal{W}_k\}$ is an open cover of X^m .

But then $\cup_{k=1}^{\infty} \mathcal{W}_k$ is an ω -cover of X .

■

None of our classes are closed under finite products. Todorćević [19] showed that there exist two (nonmetrizable) topological spaces X and Y

that satisfy $\mathcal{S}_1(\Omega, \Gamma)$ (γ -set), but whose product does not satisfy $\mathcal{U}_{fin}(\Gamma, \mathcal{O})$ (Menger). Thus none of our properties are closed under finite products.

If we restrict our attention to separable metric spaces it also is the case assuming CH that none of our classes are closed under finite products. For the class $\mathcal{S}_1(\Omega, \Gamma)$ note that Galvin-Miller [5] using a result of Todorcevic showed that there are γ -sets whose product is not a γ -set. For the classes $\mathcal{S}_1(\Omega, \Omega)$ and $\mathcal{S}_{fin}(\Omega, \Omega)$ construct a pair of generic Lusin sets H_0 and H_1 such that $H_0 + H_1 = \mathbb{Z}^\omega$

Remark The special Lusin set L gives a partial answer to a problem of Lelek (see [11]). It shows that it is relatively consistent with ZFC that there exists a separable metrizable space L that has property $\mathcal{U}_{fin}(\Gamma, \mathcal{O})$, but does not have property $\mathcal{U}_{fin}(\Gamma, \mathcal{O})$ in each finite power. In Lelek, $\mathcal{U}_{fin}(\Gamma, \mathcal{O})$ is referred to as the ‘‘Hurewicz property’’ in contrast to our naming it the ‘‘Menger property.’’

Remark It is relatively consistent with ZFC that for every $n \geq 1$ there exists a separable metric space X such that X^n has property $\mathcal{U}_{fin}(\Gamma, \mathcal{O})$, but X^{n+1} does not have property $\mathcal{U}_{fin}(\Gamma, \mathcal{O})$ (see Just [10] and Stamp [18]).

Remark It was shown in Just [9] that preservation of $\mathcal{U}_{fin}(\Gamma, \Omega)$ under direct sums is independent of ZFC.

Finite or countable unions

It is well-known and easy to prove that each of the classes

- $\mathcal{S}_{fin}(\mathcal{O}, \mathcal{O})$ (Rothberger property C''),
- $\mathcal{U}_{fin}(\Gamma, \Gamma)$ (Hurewicz property), and
- $\mathcal{U}_{fin}(\Gamma, \mathcal{O})$ (Menger property)

are closed under taking countable unions. It also easy to prove that $\mathcal{S}_1(\Gamma, \Lambda)$ is closed under taking countable unions. The class $\mathcal{S}_1(\Omega, \Gamma)$ (γ -sets) is not closed under taking finite unions (see Galvin-Miller [6]).

Problem 5 *Which of the remaining classes are closed under taking finite or countable unions?*

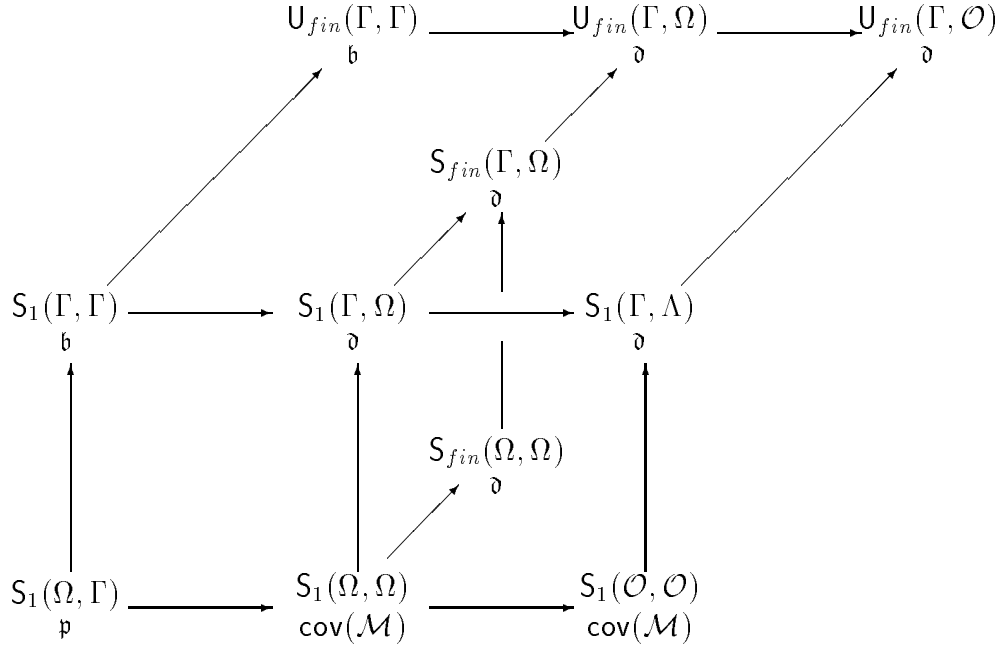

Figure 4: Cardinals $\text{non}(P)$

4 Cardinal equivalents

We now consider the connection between the properties and some well known cardinal invariants of $P(\omega)/Fin$. See Vaughan [20] for the definitions, but briefly:

\mathfrak{p} is least cardinality of a family of sets in $[\omega]^\omega$ with the finite intersection property but no pseudo intersection,

\mathfrak{d} is the minimal cardinality of a dominating family in ω^ω ,

\mathfrak{b} the minimal cardinality of an unbounded family in ω^ω , and

$\text{cov}(\mathcal{M})$ is the minimal cardinality of a covering of the real line by meager sets.

In particular, if P is one of the eleven properties in the diagram (figure 3) or is one of the splitting properties $\text{Split}(\Omega, \Omega)$ or $\text{Split}(\Lambda, \Lambda)$, we will determine:

$\text{non}(P):=$

the minimum cardinality of a set of reals that fails to have property P .

Note obviously that if $P \rightarrow Q$, then $\text{non}(P) \leq \text{non}(Q)$. Some of these cardinals are well known and we simply state the results and refer the reader to the appropriate sources.

Theorem 4.1 (*Galvin-Miller [5]*) $\text{non}(S_1(\Omega, \Gamma)) = \mathfrak{p}$.

Theorem 4.2 (*Fremlin-Miller [4]*) $\text{non}(S_1(\mathcal{O}, \mathcal{O})) = \text{cov}(\mathcal{M})$.

Theorem 4.3 (*Hurewicz [8]*) A set X is $U_{fin}(\Gamma, \Gamma)$ if and only if every continuous image of X in ω^ω is bounded. Hence $\text{non}(U_{fin}(\Gamma, \Gamma)) = \mathfrak{b}$.

Theorem 4.4 (*Hurewicz [8]*) A set X is $U_{fin}(\Gamma, \mathcal{O})$ if and only if every continuous image of X in ω^ω is not dominating. Hence $\text{non}(U_{fin}(\Gamma, \mathcal{O})) = \mathfrak{d}$.

Next we determine $\text{non}(P)$ for all the other properties in figure 3 in the introduction.

Theorem 4.5 $\text{non}(S_1(\Gamma, \Omega)) = \mathfrak{d}$.

Proof:

Since $S_1(\Gamma, \Omega) \subseteq U_{fin}(\Gamma, \mathcal{O})$ we have that

$$\text{non}(S_1(\Gamma, \Omega)) \leq \text{non}(U_{fin}(\Gamma, \mathcal{O})).$$

Also by Theorem 4.4 we have $\text{non}(U_{fin}(\Gamma, \mathcal{O})) = \mathfrak{d}$, so $\text{non}(S_1(\Gamma, \Omega)) \leq \mathfrak{d}$.

Conversely, suppose that X is a set of reals that fails to be $S_1(\Gamma, \Omega)$. Fix a sequence of γ -covers $(\mathcal{U}_n)_{n \in \omega}$ witnessing the failure of $S_1(\Gamma, \Omega)$. Fix an enumeration of each cover $\mathcal{U}_n = \{U_n^i : i \in \omega\}$. For each finite set $F \subseteq X$ define $f_F \in \omega^\omega$ by

$$f_F(n) = \min\{i : \forall j > i, F \subseteq U_n^i\}.$$

As each \mathcal{U}_n is a γ -cover, if $i > f_F(n)$, then $F \subseteq U_n^i$. Therefore,

$$\{f_F : F \in [X]^{<\omega}\}$$

must be a dominating family. Otherwise there is a g not dominated by any such f_F . I.e., for each finite $F \subseteq X$, there is an integer n such that $g(n) > f_F(n)$. This implies that $\{U_n^{g(n)} : n \in \omega\}$ is an ω -cover, contradicting the failure of $S_1(\Gamma, \Omega)$. So $\text{non}(S_1(\Gamma, \Omega)) \geq \mathfrak{d}$.

■

Theorem 4.6 $\text{non}(\mathcal{S}_{fin}(\Omega, \Omega)) = \mathfrak{d}$.

Proof:

Identical to the proof of 4.5. One only needs to modify the definition of f_F to

$$f_F(n) = \min\{i : F \subseteq U_n^i\}$$

and take $\mathcal{V}_n = \{U_n^i : i \leq g(n)\}$.

■

Theorem 4.7 $\text{non}(\mathcal{S}_1(\Gamma, \Gamma)) = \mathfrak{b}$.

Proof:

Using $\mathcal{S}_1(\Gamma, \Gamma) \subseteq \mathcal{U}_{fin}(\Gamma, \Gamma)$ and Theorem 4.3 it follows that

$$\text{non}(\mathcal{S}_1(\Gamma, \Gamma)) \leq \mathfrak{b}.$$

Conversely, suppose that X is a set of reals and that $(\mathcal{U}_n)_{n \in \omega}$ is a sequence of γ -covers witnessing the failure of $\mathcal{S}_1(\Gamma, \Gamma)$. For each $x \in X$ define $f_x \in \omega^\omega$ by

$$f_x(n) = \min\{i : \forall j \geq i, x \in U_n^j\}.$$

If g were to dominate each f_x , then $(U_n^{g(n)})_{n \in \omega}$ would be a γ -cover, a contradiction. Therefore $\{f_x : x \in X\}$ is an unbounded family. Hence $\text{non}(\mathcal{S}_1(\Gamma, \Gamma)) \geq \mathfrak{b}$.

■

Theorem 4.8 $\text{non}(\mathcal{S}_1(\Omega, \Omega)) = \text{cov}(\mathcal{M})$.

Proof:

The inclusion $\mathcal{S}_1(\Omega, \Omega) \subseteq \mathcal{S}_1(\mathcal{O}, \mathcal{O})$ and Theorem 4.2 give us the inequality $\text{non}(\mathcal{S}_1(\Omega, \Omega)) \leq \text{cov}(\mathcal{M})$.

Conversely fix X a set of reals and $(\mathcal{U}_n)_{n \in \omega}$ a sequence of ω -covers witnessing the failure of $\mathcal{S}_1(\Omega, \Omega)$. For each finite $F \subseteq X$ let

$$K_F = \{f \in \omega^\omega : (\forall n \in \omega)(F \not\subseteq U_n^{f(n)})\}.$$

Since for each $f \in \omega^\omega$ there is a finite $F \subseteq X$ such that $F \not\subseteq U_n^{f(n)}$, we have that $\omega^\omega = \bigcup \{K_F : F \in [X]^{<\omega}\}$. Furthermore, each K_F is closed and nowhere dense. Hence $\text{non}(\mathcal{S}_1(\Omega, \Omega)) \geq \text{cov}(\mathcal{M})$.

■

Our results are summarized in figure 4. Classical results about the relationships between the cardinals \mathfrak{p} , \mathfrak{b} , \mathfrak{d} and $\text{cov}(\mathcal{M})$ give alternative proofs that many of the implications in our diagram cannot be reversed.

Split(Λ, Λ) and Split(Ω, Ω)

These properties were defined in Scheepers [16]: for classes of covers \mathcal{A} and \mathcal{B} , a space has property $\text{Split}(\mathcal{A}, \mathcal{B})$ iff every open cover $\mathcal{U} \in \mathcal{A}$ can be partitioned into two subcovers \mathcal{U}_0 and \mathcal{U}_1 both in \mathcal{B} . Recall that a family $\mathcal{R} \subseteq [\omega]^\omega$ is said to be a *reaping family* if for each $x \in [\omega]^\omega$ there is a $y \in \mathcal{R}$ such that either $y \subseteq^* x$ or $y \subseteq^* \omega \setminus x$. The minimal cardinality of a reaping family is denoted by \mathfrak{r} , and the minimal cardinality of a base for a nonprincipal ultrafilter is denoted by \mathfrak{u} . In the proofs of the next two theorems we will use the families

$$\mathcal{U} = \{B_n^1 : n \in \omega\} \text{ and } \mathcal{V} = \{B_n^0 : n \in \omega\}$$

where

$$B_n^1 = \{x \in [\omega]^\omega : n \in x\} \text{ and } B_n^0 = \{x \in [\omega]^\omega : n \notin x\}.$$

Note that \mathcal{U} and \mathcal{V} are large covers of any subset of $[\omega]^\omega$ and $\mathcal{U} \cup \mathcal{V}$ is a subbase for the topology. We will refer to \mathcal{U} as the canonical large cover.

Theorem 4.9 $\text{non}(\text{Split}(\Lambda, \Lambda)) = \mathfrak{r}$.

Proof:

Suppose that $X \subseteq [\omega]^\omega$ is a reaping family. Therefore the cover \mathcal{U} cannot be partitioned into two large subcovers. Conversely, suppose that X is a set of reals and $\{U_n : n \in \omega\}$ is a large cover of X . For each $x \in X$ let

$$A_x = \{n \in \omega : x \in U_n\}.$$

If \mathcal{F} is the collection of all such A_x 's, then \mathcal{F} is a reaping family. For if $A \subseteq \omega$ is such that for all $x \in X$ both $A_x \cap A$ and $A_x \setminus A$ are infinite, then

$$\{U_n : n \in A\} \cup \{U_n : n \notin A\}$$

is a splitting of $\{U_n : n \in \omega\}$ into disjoint large subcovers.

■

The proof yields a bit more.

Theorem 4.10 *A set of reals X is $\text{Split}(\Lambda, \Lambda)$ with respect to clopen covers if and only if every continuous image of X in $[\omega]^\omega$ is not a reaping family.*

Proof:

Suppose that X is a set of reals, $f : X \rightarrow [\omega]^\omega$ is continuous and that $f(X)$ is a reaping family. The canonical large cover is in fact a clopen family. Therefore the collection $f^{-1}(\mathcal{U}) = \{f^{-1}(B_n^1) : n \in \omega\}$ is a large clopen cover of X . Suppose $f^{-1}(\mathcal{U}) = \mathcal{V}_0 \cup \mathcal{V}_1$ is a partition. Then we have the corresponding partition of $\omega = A_0 \cup A_1$ where $\mathcal{V}_i = \{f^{-1}(U_n) : n \in A_i\}$. As $f(X)$ is a reaping family, there is an $x \in X$ such that for either $i = 0$ or 1 , $f(x) \subseteq^* A_i$. Then \mathcal{V}_i is not large at x . Therefore X is not $\text{Split}(\Lambda, \Lambda)$ with respect to the clopen cover $f^{-1}(\mathcal{U})$.

Conversely, suppose that X is not $\text{Split}(\Lambda, \Lambda)$ with respect to some large clopen cover $\{U_n : n \in \omega\}$. For each $x \in X$ define $f_x \in [\omega]^\omega$ by $n \in f_x$ iff $x \in U_n$. Since the cover is large, each f_x is infinite. As above, since $\{U_n : n \in \omega\}$ cannot be split, $\{f_x : x \in X\}$ is a reaping family. Therefore it suffices to check that the mapping $f : x \rightarrow f_x$ is continuous. But the collection of $\{B_n^i : n \in \omega, i = 0, 1\}$ forms a subbase for $[\omega]^\omega$, and clearly $f^{-1}(B_n^1) = U_n$ and $f^{-1}(B_n^0) = X \setminus U_n$ therefore f is continuous (this is the only place where we need the restriction to clopen covers).

■

Theorem 4.11 $\text{non}(\text{Split}(\Omega, \Omega)) = \mathfrak{u}$.

Proof:

Suppose that $X \subseteq [\omega]^\omega$ is a filter-base. Then the canonical large cover in $[\omega]^\omega$ is in fact an ω -cover of X . If X is a base for an ultrafilter, then this cover cannot be partitioned into two ω -subcovers.

Conversely, suppose that X is a set of reals and \mathcal{W} is an ω -cover of X . For each $x \in X$ let

$$\mathcal{W}_x = \{U \in \mathcal{W} : x \in U\}.$$

If \mathcal{F} is the collection of all such \mathcal{W}_x 's, then \mathcal{F} forms a filterbase on \mathcal{W} and if \mathcal{W} cannot be split into two ω -covers, then \mathcal{F} generates a nonprincipal ultrafilter.

■

Analogously to Theorem 4.10 we can prove:

Theorem 4.12 *A set of reals X is $\text{Split}(\Omega, \Omega)$ with respect to clopen covers if and only if every continuous image of X in $[\omega]^\omega$ does not generate an ultrafilter.*

Note that a base for an ultrafilter is a reaping family, and therefore $\tau \leq u$. In [2] it is proven consistent that this inequality may be strict. Therefore $\text{Split}(\Lambda, \Lambda) \not\Rightarrow \text{Split}(\Omega, \Omega)$. Similarly neither τ nor u are comparable to \mathfrak{d} , therefore there are no implications between either $\text{Split}(\Lambda, \Lambda)$ or $\text{Split}(\Omega, \Omega)$ and any of the six classes in figure 4 whose ‘non’ is equivalent to \mathfrak{d} . In Scheepers [16] it is shown that

- $\mathbf{U}_{fin}(\Gamma, \Gamma) \Rightarrow \text{Split}(\Lambda, \Lambda)$ (Cor 29), and
- $\mathbf{S}_1(\mathcal{O}, \mathcal{O}) \Rightarrow \text{Split}(\Lambda, \Lambda)$ (Thm 15).

Note that while both $\mathfrak{b} \leq \tau$ and $\text{cov}(\mathcal{M}) \leq \tau$, it is consistent that these inequalities are strict (see Vaughan [20]). So neither of these implications can be reversed.

Problem 6 *Does $\text{Split}(\Omega, \Omega) \Rightarrow \text{Split}(\Lambda, \Lambda)$?*

5 The Hurewicz Conjecture and the Borel Conjecture.

Every σ -compact space belongs to $\mathbf{U}_{fin}(\Gamma, \Gamma)$. It is also well-known that not every space belonging to $\mathbf{U}_{fin}(\Gamma, \Gamma)$ need be σ -compact. We now look at the traditional examples of sets of reals belonging to $\mathbf{U}_{fin}(\Gamma, \Gamma)$, and show that some of these belong to $\mathbf{S}_1(\Gamma, \Gamma)$, while others do not. Since $\mathbf{S}_1(\Gamma, \Gamma)$ is contained in $\mathbf{S}_1(\Gamma, \Lambda)$, and the unit interval is not an element of $\mathbf{S}_1(\Gamma, \Lambda)$, we see that the σ -compact spaces do not in general belong to the class $\mathbf{S}_1(\Gamma, \Gamma)$.

On page 200 of [7], W. Hurewicz conjectures:

[Hurewicz] A set of real numbers has property $\mathbf{U}_{fin}(\Gamma, \Gamma)$ if, and only if, it is σ -compact.⁵

The existence of a Sierpiński set violates this conjecture. As we have seen earlier, Sierpiński sets are elements of $\mathbf{S}_1(\Gamma, \Gamma)$.

The following result shows that Hurewicz's conjecture fails in ZFC.

Theorem 5.1 *There exists a separable metric space X such that $|X| = \omega_1$, X is not σ -compact and X has property $\mathbf{U}_{fin}(\Gamma, \Gamma)$. This X also has property $\mathbf{S}_1(\Gamma, \Omega)$ and $\mathbf{S}_{fin}(\Omega, \Omega)$.*

Proof:

Case 1. $\mathfrak{b} > \omega_1$.

In this case every X of size ω_1 is in $\mathbf{S}_1(\Gamma, \Gamma)$ and $\mathbf{S}_{fin}(\Omega, \Omega)$, hence in both $\mathbf{U}_{fin}(\Gamma, \Gamma)$ and $\mathbf{S}_1(\Gamma, \Lambda)$. (by Theorems 4.6 and 4.7).

Case 2. $\mathfrak{b} = \omega_1$.

In this case we will use a construction similar to one in [5]. Build an ω_1 -sequence $(x_\alpha : \alpha < \omega_1)$ of elements of $[\omega]^\omega$ such that $\alpha < \beta$ implies $x_\beta \subseteq^* x_\alpha$ and if $f_\alpha : \omega \rightarrow x_\alpha$ is the increasing enumeration of x_α , then for every $g \in \omega^\omega$ there exists α such that for infinitely many n we have $g(n) < f_\alpha(n)$.

Claim 5.2 *For any $S \in [\omega]^\omega$ there exists $\alpha < \omega_1$ such that there exists infinitely many n such that $|(f_\alpha(n), f_\alpha(n+1)) \cap S| \geq 2$.*

To prove Claim 5.2 suppose not and let g eventually dominate all the increasing enumerations of sets S^* such that $S^* =^* S$. Then g eventually dominates the f_α 's, contradiction. This completes the proof of Claim 5.2.

Claim 5.3 *Let $X = [\omega]^{<\omega} \cup \{x_\alpha : \alpha < \omega_1\}$. Then for every sequence $(\mathcal{U}_n : n \in \omega)$ of ω -covers of X (or even just of $[\omega]^{<\omega}$) there exists an $A \in [\omega]^\omega$, $(V_n \in \mathcal{U}_n : n \in A)$ and $\alpha < \omega_1$ such that for all $\beta \geq \alpha$ we have $x_\beta \in V_n$ for all but finitely many $n \in A$.*

To prove Claim 5.3 construct a sequence $(k_n : n \in \omega)$ in ω , such that there exists $V_n \in \mathcal{U}_n$ with the property that

$$\{x \subseteq \omega : x \cap (k_n, k_{n+1}) = \emptyset\} \subseteq V_n.$$

⁵“Es entsteht nun die Vermutung dass durch die (warscheinlich schärfere) Eigenschaft E^{**} die halbkompakten Mengen F_σ allgemein charakterisiert sind.”

To do this use that \mathcal{U}_n is a ω -cover to pick $V_n \supseteq [k_n + 1]^{<\omega}$ and then for each $s \in [k_n + 1]^{<\omega}$ fix a basic open set V_s such that $s \in V_s \subseteq V_n$ and let n_s be the maximum of the support of V_s . Then $k_{n+1} = \max\{n_s : s \in [k_n + 1]^{<\omega}\}$ suffices. It follows from Claim 5.2 that there exist $\alpha < \omega_1$, $A \in [\omega]^\omega$ and an increasing sequence $(m_n : n \in A)$ such that for every $n \in A$

$$\{x \subseteq \omega : x \cap (f_\alpha(m_n), f_\alpha(m_n + 1)) = \emptyset\} \subseteq V_n.$$

It follows $x_\beta \in V_n$ for all $\beta \geq \alpha$ for all but finitely many $n \in A$. This completes the proof of Claim 5.3.

Now we show that our set X in this case is in both $\mathbf{U}_{fin}(\Gamma, \Gamma)$ and $\mathbf{S}_1(\Omega, \Omega)$ (and hence $\mathbf{S}_1(\Gamma, \Lambda)$). First we show that it satisfies a property we might call $\mathbf{S}_1(\Gamma, \Gamma)^*$.

Given any sequence $(\mathcal{U}_n : n \in \omega)$ of γ -covers of X , there exist $(V_n \in \mathcal{U}_n : n \in \omega)$ and a countable $Y \subseteq X$ such that $(V_n : n \in \omega)$ is a γ -cover of $X \setminus Y$.

If $\mathbf{S}_{fin}(\Gamma, \Gamma)^*$ is defined analogously, then it is easy to see using the same proof as for Theorem 1.1 that $\mathbf{S}_{fin}(\Gamma, \Gamma)^*$ is equivalent to $\mathbf{S}_1(\Gamma, \Gamma)^*$. Clearly Claim 5.3 implies $\mathbf{S}_{fin}(\Gamma, \Gamma)^*$.

$\mathbf{S}_1(\Gamma, \Gamma)^*$ implies $\mathbf{U}_{fin}(\Gamma, \Gamma)$ because we may first pick a γ -cover $(V_n \in \mathcal{U}_n : n \in \omega)$ of $X \setminus Y$ and then pick a γ -cover $(W_n \in \mathcal{U}_n : n \in \omega)$ of Y . Then $(V_n \cup W_n : n \in \omega)$ is a γ -cover of X .

■

To see that X is in $\mathbf{S}_1(\Omega, \Omega)$ we need the following claim:

Claim 5.4 *For every $B \in [\omega]^\omega$, sequence $(\mathcal{U}_n : n \in B)$ of ω -covers of X , and countable $Y \subseteq X$ there exist $A \in [B]^\omega$, $(V_n \in \mathcal{U}_n : n \in A)$ and a countable $Z \subseteq X$ such that Y and Z are disjoint and $(V_n \in \mathcal{U}_n : n \in A)$ is a γ -cover of $X \setminus Z$.*

Proof:

Let $Y = \{y_n : n \in \omega\}$ and apply Claim 5.3 to the ω -covers defined by

$$\mathcal{U}'_n = \{U \in \mathcal{U}_n : \{y_i : i < n\} \subseteq U\}$$

for $n \in B$. This completes the proof of Claim 5.4.

Using Claim 5.4 for every sequence $(\mathcal{U}_n : n \in \omega)$ of ω -covers of X inductively construct $A_i \in [\omega]^\omega$, $(V_n \in \mathcal{U}_n : n \in A_i)$ and $Y_i \subseteq X$ countable such that

- $A_i \cap A_j = \emptyset$ for $i \neq j$.
- $Y_i \cap Y_j = \emptyset$ for $i \neq j$.
- $(V_n \in \mathcal{U}_n : n \in A_i)$ is a γ -cover of $X \setminus Y_i$.

(At stage n take $Y = \cup\{Y_i : i < n\}$ and $B = \omega \setminus (\cup\{A_i : i < n\})$. Apply Claim 5.3 and let $Y_n = Z$ and cut down A_n , if necessary, to ensure that $\cup\{A_i : i \leq n\}$ is coinfinite.)

Since the $\{Y_i : i < \omega\}$ and the $\{A_i : i < \omega\}$ are pairwise disjoint families, letting $A = \cup_{i \in \omega} A_i$, $(V_n : n \in A)$ is an ω -cover of X . Hence X has property $S_1(\Omega, \Omega)$. This completes the proof of Theorem 5.1.

■

Problem 7 *Is the set X constructed in Case 2 of Theorem 5.1 a γ -set, i.e., $S_1(\Omega, \Gamma)$?*

The Borel conjecture implies that every set in $S_1(\mathcal{O}, \mathcal{O})$ is countable (hence every set in $S_1(\Omega, \Omega)$ or $S_1(\Omega, \Gamma)$ is countable). Theorem 5.1 and the Cantor set along with the last example rules out an analogous conjecture for all except $S_1(\Gamma, \Gamma)$. So we ask:

Problem 8 *Is it consistent, relative to the consistency of ZF, that every set in $S_1(\Gamma, \Gamma)$ is countable?*

One may also ask if all the pathological examples of sets having property $U_{fin}(\Gamma, \Gamma)$ occur because of the presence of such sets in $S_1(\Gamma, \Gamma)$; here is one formalization of this question.

Problem 9 *Let X be a set of real numbers which does not contain a perfect set of real numbers but which does have the Hurewicz property. Does X then belong to $S_1(\Gamma, \Gamma)$?*

$U_{fin}(\Gamma, \Gamma)$ and perfectly meager sets.

We now prove a theorem which implies that the $\mathcal{S}_1(\Gamma, \Gamma)$ -sets are contained in another class of sets that were introduced in the early parts of this century. Recall that a set X of real numbers is *perfectly meager* (also called “always of first category”) if, for every perfect set P of real numbers, $X \cap P$ is meager in the relative topology of P .

Theorem 5.5 *If a set of reals X is in $\mathcal{U}_{fin}(\Gamma, \Gamma)$ and contains no perfect subset, then X is perfectly meager.*

Proof:

Let P be a perfect set of real numbers. Since X contains no perfect set, $P \setminus X$ is a dense subset of P . Let D be a countable dense subset of P which is contained in $P \setminus X$, and enumerate D bijectively as $(d_n : n = 1, 2, 3, \dots)$.

Fix k . For each x in X choose open intervals I_x^k and J_x^k such that

1. I_x^k is centered at x ,
2. J_x^k is centered at d_k , and
3. the closures of these intervals are disjoint.

Let $\{I_{x_n}^k : n = 1, 2, 3, \dots\}$ be a countable subset of $\{I_x^k : x \in X\}$ which covers X . Then for each n define $I_n^k = \cup_{j \leq n} I_{x_j}^k$, and $J_n^k = \cap_{j \leq n} J_{x_j}^k$. Then $\mathcal{U}_k = \{I_n^k : n = 1, 2, 3, \dots\}$ is a γ -cover of X .

Apply $\mathcal{U}_{fin}(\Gamma, \Gamma)$ to the sequence $(\mathcal{U}_k : k = 1, 2, 3, \dots)$. For each k we find an n_k such that $(I_{n_k}^k : k = 1, 2, 3, \dots)$ is a γ cover for X . For each j put $G_j = \cup_{k \geq j} J_{n_k}^k$. Then each $G_j \cap P$ is a dense open subset of P (as it contains all but a finite piece of D). The intersection of these sets is a dense G_δ subset of P , and is disjoint from $X \cap P$. Thus, $X \cap P$ is a meager subset of P .

■

Corollary 5.6 *Every element of $\mathcal{S}_1(\Gamma, \Gamma)$ is perfectly meager.*

Proof:

We have seen (Theorem 2.4) that sets in $\mathcal{S}_1(\Gamma, \Gamma)$ do not contain perfect sets of real numbers. But $\mathcal{S}_1(\Gamma, \Gamma) \subseteq \mathcal{U}_{fin}(\Gamma, \Gamma)$.

■

In Theorem 2 of Galvin-Miller [5] it was shown that if a subset X of the real line is in $\mathcal{S}_1(\Omega, \Gamma)$, then for every G_δ -set G which contains X , there is

an F_σ -set F such that $X \subseteq F \subseteq G$. In fact, this property characterizes $\mathbf{U}_{fin}(\Gamma, \Gamma)$.

Theorem 5.7 *For a set X of real numbers, the following are equivalent:*

1. X has property $\mathbf{U}_{fin}(\Gamma, \Gamma)$.
2. For every G_δ -set G which contains X , there is a F_σ -set F such that $X \subseteq F \subseteq G$.

Proof:

1 \Rightarrow 2: Write $G = \bigcap_{n=1}^{\infty} G_n$, where each G_n is open. Fix n , and choose for each x in X an open interval I_x^n which contains x , and whose closure is contained in G_n . Choose a countable subcover $\{I_{x_j}^n : j = 1, 2, 3, \dots\}$ of X from the cover $\{I_x^n : x \in X\}$. For each n and k define $I_k^n = \bigcup_{j \leq k} I_{x_j}^n$.

Then $\mathcal{U}_n = \{I_k^n : k = 1, 2, 3, \dots\}$ is a γ -cover of X such that for each k the closure of I_k^n is contained in G_n .

Apply the fact that X is a $\mathbf{U}_{fin}(\Gamma, \Gamma)$ -set to the sequence

$$(\mathcal{U}_n : n = 1, 2, 3, \dots).$$

For each n choose a k_n such that $(I_{k_n}^n : n = 1, 2, 3, \dots)$ is a γ -cover of X . For each n let F_n be the intersection of the closures of the sets $I_{k_m}^m$, $m \geq n$. For each n we have the closed set F_n contained in G . But then the union of the F_n 's is an F_σ -set which contains X and is contained in G .

2 \Rightarrow 1: Let $(\mathcal{U}_n : n < \omega)$ be a sequence such that each \mathcal{U}_n is a cover of X by open subsets of the real line. By assumption there exists closed sets F_n such that

$$X \subseteq \bigcup_{n < \omega} F_n \subseteq \bigcap_{n < \omega} (\bigcup \mathcal{U}_n).$$

Since the real line is σ -compact we may assume that the F_n are compact. For each n choose $\mathcal{V}_n \in [\mathcal{U}_n]^{<\omega}$ such that $(\bigcup_{m < n} F_m) \subseteq \bigcup \mathcal{V}_n$ for each n . Either there exists n such that $\bigcup \mathcal{V}_n = X$ or $\{\bigcup \mathcal{V}_n : n \in \omega\}$ is infinite and hence a γ -cover of X .

■

6 Ramseyan theorems and other properties

Other classes of spaces motivated by diagonalization of open covers are related to Q -point ultrafilters, P -point ultrafilters and Ramsey-like partition relations. If \mathcal{A} and \mathcal{B} are classes of open covers, then a space has the property

1. $Q(\mathcal{A}, \mathcal{B})$ iff for every open cover $\mathcal{U} \in \mathcal{A}$ and for every partition of this cover into countably many pairwise disjoint nonempty finite sets $\mathcal{F}_0, \mathcal{F}_1, \mathcal{F}_2, \dots$, there is a subset $\mathcal{V} \subseteq \mathcal{U}$ which belongs to \mathcal{B} such that $|\mathcal{V} \cap \mathcal{F}_n| \leq 1$ for each n and
2. $P(\mathcal{A}, \mathcal{B})$ iff for every sequence $\{\mathcal{U}_n : n \in \omega\}$ of open covers of X from \mathcal{A} such that $\mathcal{U}_{n+1} \subseteq \mathcal{U}_n$, for each n , there is an open cover \mathcal{V} which belongs to \mathcal{B} such that $\mathcal{V} \subseteq^* \mathcal{U}_n$ for each n .

In Scheepers [16] the partition relation $\Omega \rightarrow (\Omega)_2^2$ was defined: a space X is said to satisfy $\Omega \rightarrow (\Omega)_2^2$ iff for every ω -cover \mathcal{U} of X , if

$$f : [\mathcal{U}]^2 \rightarrow \{0, 1\}$$

is any coloring, then there is an $i \in \{0, 1\}$ and an ω -cover $\mathcal{V} \subseteq \mathcal{U}$ such that $f(\{A, B\}) = i$ for all A and B from \mathcal{V} . It is customary to say that \mathcal{V} is homogeneous for f .

Also in [16] it was shown that for a set X of real numbers, the following statements are equivalent:

1. X is both $S_1(\Omega, \Omega)$ and $Q(\Omega, \Omega)$.
2. Ω , the collection of ω -covers of X , satisfies the following partition relation: $\Omega \rightarrow (\Omega)_2^2$.

The next theorem shows that indeed, the partition relation characterizes the property of being a $S_1(\Omega, \Omega)$ -set.

Theorem 6.1 $S_1(\Omega, \Omega) \subseteq Q(\Omega, \Omega)$.

Proof:

Let X be a $S_1(\Omega, \Omega)$ -set and let \mathcal{U} be an ω -cover of it. Let $(\mathcal{P}_n : n < \omega)$ be a partition of this cover into pairwise disjoint finite sets. Enumerate the cover bijectively as $(U_n : n < \omega)$ such that, letting for each n the set I_n be

the j 's such that $U_j \in \mathcal{P}_n$. We get a partition $(I_n : n < \omega)$ of ω into disjoint intervals such that if m is less than n , then each element of I_m is less than each element of I_n . For each ℓ , let $m_\ell = \sum_{j \leq \ell} |I_j|$. Now define an ω -cover \mathcal{V} of X such that V is in \mathcal{V} iff

$$V = U_{k_0} \cap \dots \cap U_{k_r}$$

where

1. $r = m_{\ell_0}$ and
2. $\ell_0 < \dots < \ell_r$ are such that for each j , k_j is in I_{ℓ_j} , and
3. V is nonempty.

Since $S_1(\Omega, \Omega)$ implies $Split(\Omega, \Omega)$ (see Corollary 22 of [16]), we may choose a partition $(\mathcal{V}_n : n < \omega)$ such that each \mathcal{V}_n is an ω -cover of X , and \mathcal{V} is the union of these sets. Then, discard from each \mathcal{V}_n all sets of the form

$$U_{k_0} \cap \dots \cap U_{k_r}$$

where k_0 is an element of $I_0 \cup \dots \cup I_n$; let \mathcal{W}_n denote the resulting family. Observe that each \mathcal{W}_n is still an ω -cover.

Since X is an $S_1(\Omega, \Omega)$ -set, we find for each n a W_n in \mathcal{W}_n such that the set $\{W_n : n \in \omega\}$ is an ω -cover of X . For each n we fix a representation

$$W_n = U_{k_0^n} \cap \dots \cap U_{k_{r(n)}^n}$$

where $k_0^n < \dots < k_{r(n)}^n$. On account of the way \mathcal{W}_n was obtained from \mathcal{V}_n , we see that $n < k_0^n$ and $n < r(n)$. Now choose recursively sets

$$U_{k(0)}, U_{k(1)}, \dots, U_{k(n)}, \dots$$

so that $U_{k(0)} = U_{k_0^1} \supseteq W_1$. Suppose that $U_{k(0)}, \dots, U_{k(n)}$ have been chosen such that for $i \leq n$ we have

- $k(i) \in \{k_0^i, \dots, k_{r(i)}^i\}$ and
- $W_i \subseteq U_{k(i)}$, and
- the $k(i)$'s belong to distinct I_j 's,

To define $U_{k(n+1)}$ we consult $W_{n+1} = U_{k_0^{n+1}} \cap \dots \cap U_{k_{r(n+1)}^{n+1}}$. Since we have so far selected only $n + 1$ numbers and since $r(n + 1)$ is larger than $n + 1$, and since the k_j^{n+1} come from $r(n + 1)$ disjoint intervals I_j , we can find one of these intervals which is disjoint from $\{k(0), \dots, k(n)\}$, and select $k(n + 1)$ to be the k_j^{n+1} from that interval. This then specifies $U_{k(n+1)}$.

Because the sequence of W_n 's refines $\{U_{k(n)} : n < \omega\}$, the latter is an ω -cover of X , and by construction it contains no more than one element per \mathcal{P}_n .

■

In Scheepers [16] it was shown that if X satisfies $\mathsf{S}_{fin}(\Omega, \Omega)$, then its family of ω -covers, Ω , satisfies the partition relation

$$\Omega \rightarrow [\Omega]_2^2.$$

Satisfying this partition relation means that for every ω -cover \mathcal{U} of X , if

$$f : [\mathcal{U}]^2 \rightarrow \{0, 1\}$$

is any coloring, then there are $i \in \{0, 1\}$, an ω -cover $\mathcal{V} \subseteq \mathcal{U}$ and a finite-to-one function $q : \mathcal{V} \rightarrow \omega$ such that for all A and B from \mathcal{V} , if $q(A) \neq q(B)$, then $f(\{A, B\}) = i$. It is customary to say that \mathcal{V} is eventually homogeneous for f .

We now show that these two properties are equivalent.

Theorem 6.2 *For any space X , $\Omega \rightarrow [\Omega]_2^2$ is equivalent to $\mathsf{S}_{fin}(\Omega, \Omega)$.*

Proof:

It is shown in [16] that $\mathsf{S}_{fin}(\Omega, \Omega)$ implies $\Omega \rightarrow [\Omega]_2^2$. To prove the other direction suppose that $\mathcal{U}_n = \{U_m^n : m \in \omega\}$ is an ω -cover for each $n \in \omega$. Let

$$\mathcal{U} = \{U_k^0 \cap U_l^k : k, l \in \omega\}.$$

\mathcal{U} is an ω -cover, since given a finite $F \subseteq X$ we can first pick k with $F \subseteq U_k^0$ and then pick l with $F \subseteq U_l^k$. For each element of \mathcal{U} we pick a pair as above and define $f : [\mathcal{U}]^2 \rightarrow \{0, 1\}$ by

$$f(\{U_{k_0}^0 \cap U_{l_0}^{k_0}, U_{k_1}^0 \cap U_{l_1}^{k_1}\}) = \begin{cases} 0 & \text{if } k_0 = k_1 \\ 1 & \text{if } k_0 \neq k_1 \end{cases}$$

By applying $\Omega \rightarrow [\Omega]_2^2$ there exist a sequence (k_i, l_i) and a finite-to-one function $q : \omega \rightarrow \omega$ such that

$$\mathcal{V} = \{U_{k_i}^0 \cap U_{l_i}^{k_i} : i \in \omega\}$$

is an ω -cover of X and either

(a) $q(i) \neq q(j)$ implies $k_i = k_j$ or

(b) $q(i) \neq q(j)$ implies $k_i \neq k_j$.

In case (a), since q is finite-to-one, we get that $k_i = k_j$ for every $i, j \in \omega$. This would mean that every element of \mathcal{V} refines $U_{k_0}^0$, but this contradicts the fact that \mathcal{V} is an ω -cover. Thus this case cannot occur.

In case (b), let

$$\mathcal{W} = \{U_{l_i}^{k_i} : i < \omega\}.$$

Since \mathcal{V} refines \mathcal{W} and $X \notin \mathcal{W}$, \mathcal{W} is an ω -cover of X . Define

$$\mathcal{W}_n = \{U_{l_i}^{k_i} : k_i = n\} \subseteq \mathcal{U}_n.$$

To finish the proof it is enough to see that each \mathcal{W}_n is finite. If not, there would be an infinite $A \subseteq \omega$ such that $k_i = n$ for each $i \in A$. Since q is finite-to-one, there would be $i \neq j \in A$ with $q(i) \neq q(j)$. But $k_i = k_j = n$ contradicts the assumption of case (b).

■

References

- [1] T. Bartoszyński and M. Scheepers, *A-sets*, **Real Analysis Exchange** 19(2) (1993–1994), 521 – 528.
- [2] Murray Bell and K. Kunen, *On the π character of ultrafilters*, **C.R. Math. Acad. Sci. Canada** 3 (1981), 351–365.
- [3] P. Daniels, *Pixley-Roy spaces over subsets of the reals*, **Topology and its Applications** 29 (1988), 93–106.
- [4] D.H. Fremlin and A.W. Miller, *On some properties of Hurewicz, Menger and Rothberger*, **Fundamenta Mathematicae** 129 (1988), 17 – 33.

- [5] F. Galvin and A.W. Miller, γ -sets and other singular sets of reals, **Topology and its Applications** 17 (1984), 145–155.
- [6] J. Gerlits and Zs. Nagy, *Some properties of $C(X)$, I*, **Topology and its Applications** 14 (1982), 151 – 161.
- [7] W. Hurewicz, *Über eine Verallgemeinerung des Borelschen Theorems*, **Mathematische Zeitschrift** 24 (1925), 401 – 421.
- [8] W. Hurewicz, *Über Folgen stetiger Funktionen*, **Fundamenta Mathematicae** 9 (1927), 193 – 204.
- [9] W. Just, *On direct sums of γ_7 spaces*, handwritten notes.
- [10] W. Just, *γ_2 does not imply γ_7* , handwritten notes.
- [11] A. Lelek, *Some cover properties of spaces*, **Fundamenta Mathematicae** 64 (1969), 209 – 218.
- [12] K. Menger, *Einige Überdeckungssätze der Punktmengenlehre*, **Sitzungsberichte. Abt. 2 a, Mathematik, Astronomie, Physik, Meteorologie und Mechanik (Wiener Akademie)** 133 (1924), 421 – 444.
- [13] A. Miller, *Special subsets of real line*, **Handbook of Set Theoretic Topology**, North Holland, (1984), 201-233.
- [14] F. Rothberger, *Eine Verschärfung der Eigenschaft C* , **Fundamenta Mathematicae** 30 (1938), 50 – 55.
- [15] M. Sakai, *Property C and function spaces*, **Proceedings of the American Mathematical Society** 104 (1988), 917-919.
- [16] M. Scheepers, *Combinatorics of open covers (I): Ramsey theory*, **Topology and its Applications** 69 (1996), 31 – 62.
- [17] S. Sierpiński, *Sur le produit combinatoire de deux ensembles joissant de la propriété C* , **Fundamenta Mathematicae** 24 (1935), 48–50.
- [18] William Stamp, *Details supporting “ γ_2 does not imply γ_7 ” and “On direct sums of γ_7 spaces ”*, notes.

- [19] S. Todorčević, *Aronszajn orderings*, preprint.
- [20] Jerry E. Vaughan, *Small uncountable cardinals and topology* from Open Problems in Topology, J. van Mill and G.M. Reed, eds., **North Holland** (1990), 195–218.

Addresses

Winfried Just
Ohio University
Department of Mathematics
Athens, OH 45701-2979 USA
e-mail: just@ace.cs.ohiou.edu

Arnold W. Miller
University of Wisconsin-Madison
Department of Mathematics Van Vleck Hall
480 Lincoln Drive
Madison, Wisconsin 53706-1388, USA
e-mail: miller@math.wisc.edu
home page: <http://www.math.wisc.edu/~miller/>

Marion Scheepers
Department of Mathematics
Boise State University
Boise, Idaho 83725 USA
e-mail: marion@math.idbsu.edu

Paul J. Szeptycki
Ohio University
Department of Mathematics
Athens, OH 45701-2979 USA
e-mail: szeptyck@oucsace.cs.ohiou.edu

August 1995